



**STERLING**<sup>®</sup>  
COMMERCIAL HYDRONIC PRODUCTS

 A MESTEK COMPANY



# *Dura-Vane II*

ARCHITECTURAL FINNED TUBE RADIATION



SDVII-1R





## TABLE OF CONTENTS

Design Features.....3

JDVB 14, 20 & 24 Dimensions and Ratings.....4-6

JDVA 14, 20 & 24 Dimensions and Ratings.....7-8

JDVA 7 & JDVB 7 Dimensions and Ratings.....9

JDVA 10LI & JDVB 10LI Dimensions and Ratings.....10

JDVPB1 & JDVPB2 Dimensions and Ratings.....11-12

JDVPA1 & JDVPA2 Dimensions and Ratings.....13-14

Accessory and Installation Detail.....15-18

Design Data.....19-21

General Specifications.....22

STYLE	DESIGN
<p><b>JDV</b> Pages 4-8</p>	
<p><b>JDV 7</b> Page 9</p>	
<p><b>JDV 10LI</b> Page 10</p>	
<p><b>JDVP</b> Pages 11-14</p>	

# DESIGN FEATURES

Sterling DURA-VANE II finned tube heating combines the smooth-flowing lines of extruded aluminum linear grilles with rugged steel enclosure. It complements the linear treatment of contemporary architecture, while providing a draft-free, comfortable environment.

## ENCLOSURES

The cold rolled steel enclosures are available in 16 gauge as standard, with an option for 14 gauge. The enclosures and accessories are degreased and phosphatized and sealer coated. They are painted with a baked powder finish.



Dura-Vane II enclosures are typically provided with slip joints welded to the interior of the enclosure front skirt. Their use permits one enclosure to engage another in a firm and flush fit. Internal gussets are provided to further strengthen the enclosure.

All Sterling commercial hydronic products are made from recycled materials. Recycled material contents can be obtained from your local Sterling representative or by viewing the [www.sterlingheat.com](http://www.sterlingheat.com) website. Sterling is a participating member of USGBC-LEEDS.

## EXTRUDED ALUMINUM OUTLET GRILLES

The extruded aluminum outlet grille is provided with a clear anodized 204R1 finish. It features a unique “bull-nose” design that extends the extrusion over the top of the enclosure front skirt. It allows an extra measure of protection to help guard the painted enclosure from damage caused by incidental contact.

Forward sloping air discharge vanes direct the heated air toward the occupied areas. The outlets are 3/16" deep on 3/8" centers. The uninterrupted lineal flow of the “pencil-proof” vanes is maintained by the use of alignment pins installed between adjacent grilles. The aluminum grille is factory assembled to the enclosure front skirt.



## ELEMENTS

Sterling offers a wide variety of heating elements with aluminum fins on copper tube or steel fins on steel tube. All are available in a wide range of tube size, fin size, fin thickness and fin spacing to provide the desired heating output. The tubing is mechanically expanded to bond the fins securely for maximum heat transfer. Finally, Sterling’s element ratings are AHRI certified (where indicated).

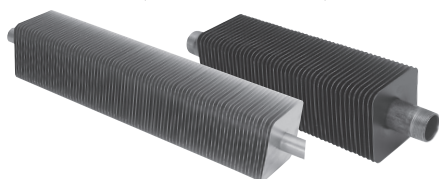

## BACKPLATE

The mounting system assures a rugged, well-fitting, quiet-operating, fast and accurate installation.

All full backplates will be one piece construction, 20 gauge galvanized steel (18 gauge optional) with a die-formed mounting channel into which the enclosure shall self-locate and secure. Self-adhesive closed cell neoprene air seal gasket to be provided when requested to prevent dirt streaking (specify factory or field installed).

All partial backplates are to be machine roll formed, pre-painted, 20 gauge steel with formed mounting channel into which the enclosure shall self-locate and secure. 18 gauge partial backplates will be provided as galvanized finish. Self-adhesive closed cell neoprene air seal gasket to be provided when requested to prevent dirt streaking (specify factory or field installed).

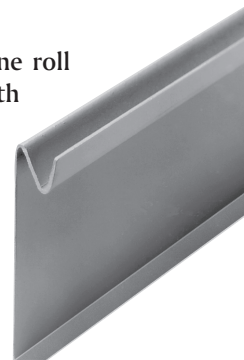

## BRACKET HANGERS

All brackets and hangers are to be die-formed 14 gauge galvanized steel with channel type wiped edge construction for rigidity. Nickel-chromium plated ball bearings inserted into a nylon isolator insert are to be used in conjunction with an 18 gauge galvanized die-formed element support cradle to provide friction-free lateral movement during expansion and contraction. Brackets are to have pre-formed contour at the top allowing the bracket to interlock with the backplate channel. Brackets are to be self-locating in the vertical (height) position. Hangers are to provide for vertical element adjustment when pitch is required (steam). Water jobs will not require adjustable hangers. Full engagement enclosure locks are to be supplied with each bracket. Bracket locations are recommended to be 2'6" to 4'0" on center located not more than 12" in from ends of enclosure based on individual design applications.



## FINISH

Dura-Vane II enclosures and accessories are provided with a factory applied baked powder finish. Twelve standard colors are available, including three metallic colors at an additional cost. Custom colors can be formulated to match any décor.

# STYLES JDVB 14, 20 & 24 DURAVANE II

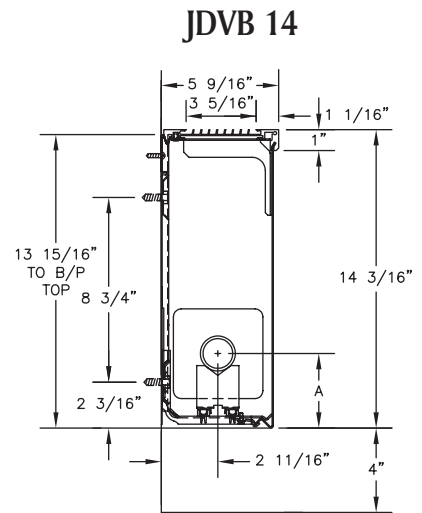
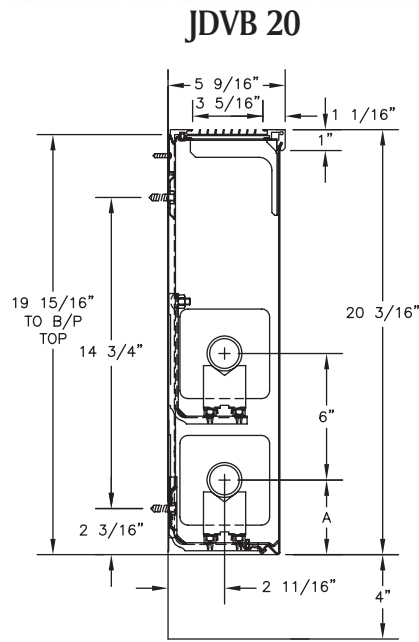
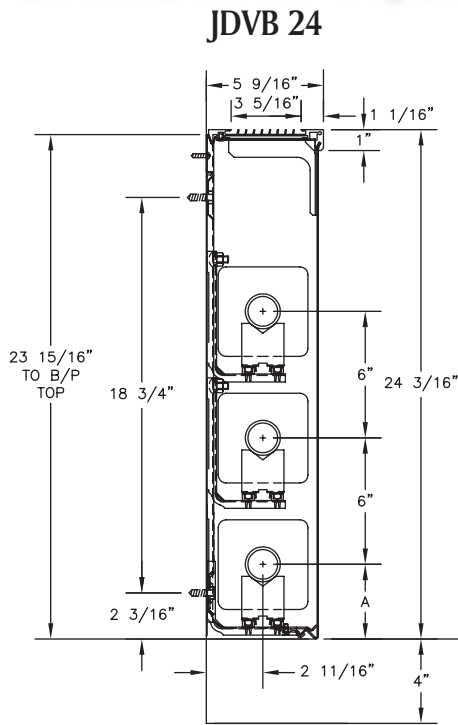

ELEMENT TUBE SIZE	CRADLE NO.	A MIN.
3/4 COPPER	2	3
1" COPPER	2	3 3/16
1 1/4 COPPER	2	3 5/16
1 1/4 STEEL	2	3 1/2
2" STEEL	1	3 1/4

CAT-72724A

STEEL ELEMENT					ENCLOSURE DEPTH IN INCHES	ENCLOSURE HEIGHT IN INCHES	TIERS AND CENTERS IN INCHES	MTG. HEIGHT IN INCHES	STEAM 215° FACTOR	Hot Water (AVG.)					
I.P.S. SIZE	CATALOG DESIGNATION	FIN SIZE IN INCHES	FIN/FT	FIN THICKNESS						200°	190°	180°	170°	160°	150°
										Factor					
1-1/4"	†S143	4-1/4" SQ.	32	0.032"	5-9/16	14-3/16	1	18-3/16	1200	1030	940	830	730	640	540
						20-3/16	1	24-3/16	1260	1080	980	870	770	670	570
						"	2-6 CL	"	2060	1770	1610	1420	1260	1090	930
						24-3/16	1	28-3/16	1300	1120	1010	900	790	690	580
						"	2-6 CL	"	2100	1810	1640	1450	1280	1110	950
1-1/4"	†S144	4-1/4" SQ.	40	0.032"	5-9/16	14-3/16	1	18-3/16	1430	1230	1120	990	870	760	640
						20-3/16	1	24-3/16	1520	1310	1190	1050	930	810	680
						"	2-6 CL	"	2240	1930	1750	1550	1370	1190	1010
						24-3/16	1	28-3/16	1590	1370	1240	1100	970	840	720
						"	2-6 CL	"	2300	1980	1790	1590	1400	1210	1040
2"	†S242	4-1/4" SQ.	25	0.032"	5-9/16	14-3/16	1	18-3/16	1090	940	850	750	670	580	490
						20-3/16	1	24-3/16	1130	970	880	780	690	600	510
						"	2-6 CL	"	1830	1570	1430	1260	1120	970	820
						24-3/16	1	28-3/16	1150	990	900	790	700	610	520
						"	2-6 CL	"	1850	1590	1440	1280	1130	980	830
2"	†S243	4-1/4" SQ.	32	0.032"	5-9/16	14-3/16	1	18-3/16	1290	1110	1010	890	790	680	580
						20-3/16	1	24-3/16	1330	1140	1040	920	810	710	600
						"	2-6 CL	"	2030	1750	1580	1400	1240	1080	910
						24-3/16	1	28-3/16	1380	1190	1080	950	840	730	620
						"	2-6 CL	"	2060	1770	1610	1420	1260	1090	930
"	2-10 CL	"	2210	1900	1720	1530	1350	1170	1000						

†NPT threads furnished on steel elements. Please use domestic fittings for proper installation.



# STYLES JDVB 14, 20 & 24 DURAVANE II

COPPER/ALUMINUM ELEMENT					ENCLOSURE DEPTH IN INCHES	ENCLOSURE HEIGHT IN INCHES	TIERS AND CENTERS IN INCHES	MTG. HEIGHT IN INCHES	STEAM 215° FACTOR	Hot Water (AVG.)					
TUBE SIZE	CATALOG DESIGNATION	FIN SIZE IN INCHES	FIN/FT	FIN THICKNESS						200°	190°	180°	170°	160°	150°
										Factor					
3/4"	C3/4-434	4-1/4 x 3-5/8	40	0.020"	5-9/16	14-3/16	1	18-3/16	1620	1390	1260	1120	990	860	730
						20-3/16	1	24-3/16	1710	1470	1330	1180	1040	910	770
						"	2-6 CL	"	2390	2060	1860	1650	1460	1270	1080
						24-3/16	1	28-3/16	1800	1550	1400	1240	1100	950	810
						"	2-6 CL	"	2490	2140	1940	1720	1520	1320	1120
						"	2-10 CL	"	2550	2190	1990	1760	1560	1350	1150
3/4"	C3/4-435	4-1/4 x 3-5/8	50	0.020"	5-9/16	14-3/16	1	18-3/16	1780	1530	1390	1230	1090	940	800
						20-3/16	1	24-3/16	1940	1670	1510	1340	1180	1030	870
						"	2-6 CL	"	2400	2060	1870	1660	1460	1270	1080
						24-3/16	1	28-3/16	2080	1790	1620	1440	1270	1100	940
						"	2-6 CL	"	2530	2180	1970	1750	1540	1340	1140
						"	2-10 CL	"	2660	2290	2070	1840	1620	1410	1200
1"	C433	4-1/4 x 3-5/8	32	0.020"	5-9/16	14-3/16	1	18-3/16	1410	1210	1100	970	860	750	630
						20-3/16	1	24-3/16	1450	1250	1130	1000	880	770	650
						"	2-6 CL	"	2320	2000	1810	1600	1420	1230	1040
						24-3/16	1	28-3/16	1480	1270	1150	1020	900	780	670
						"	2-6 CL	"	2410	2070	1880	1660	1470	1280	1080
						"	2-10 CL	"	2460	2120	1920	1700	1500	1300	1110
1"	C434	4-1/4 x 3-5/8	40	0.020"	5-9/16	14-3/16	1	18-3/16	1690	1450	1320	1170	1030	900	760
						20-3/16	1	24-3/16	1800	1550	1400	1240	1100	950	810
						"	2-6 CL	"	2510	2160	1960	1730	1530	1330	1130
						24-3/16	1	28-3/16	1890	1630	1470	1300	1150	1000	850
						"	2-6 CL	"	2660	2290	2070	1840	1620	1410	1200
						"	2-10 CL	"	2770	2380	2160	1910	1690	1470	1250
1"	C435	4-1/4 x 3-5/8	50	0.020"	5-9/16	14-3/16	1	18-3/16	1850	1590	1440	1280	1130	980	830
						20-3/16	1	24-3/16	2030	1750	1580	1400	1240	1080	910
						"	2-6 CL	"	2510	2160	1960	1730	1530	1330	1130
						24-3/16	1	28-3/16	2170	1870	1690	1500	1320	1150	980
						"	2-6 CL	"	2660	2290	2070	1840	1620	1410	1200
						"	2-10 CL	"	2770	2380	2160	1910	1690	1470	1250
1-1/4"	C1433	4-1/4 x 3-5/8	32	0.020"	5-9/16	14-3/16	1	18-3/16	1380	1190	1080	950	840	730	620
						20-3/16	1	24-3/16	1420	1220	1110	980	870	750	640
						"	2-6 CL	"	2280	1960	1780	1570	1390	1210	1030
						24-3/16	1	28-3/16	1450	1250	1130	1000	880	770	650
						"	2-6 CL	"	2370	2040	1850	1640	1450	1260	1070
						"	2-10 CL	"	2410	2070	1880	1660	1470	1280	1080
1-1/4"	C1434	4-1/4 x 3-5/8	40	0.020"	5-9/16	14-3/16	1	18-3/16	1660	1430	1290	1150	1010	880	750
						20-3/16	1	24-3/16	1760	1510	1370	1210	1070	930	790
						"	2-6 CL	"	2460	2120	1920	1700	1500	1300	1110
						24-3/16	1	28-3/16	1850	1590	1440	1280	1130	980	830
						"	2-6 CL	"	2600	2240	2030	1790	1590	1380	1170
						"	2-10 CL	"	2730	2350	2130	1880	1670	1450	1230
1-1/4"	C1435	4-1/4 x 3-5/8	50	0.020"	5-9/16	14-3/16	1	18-3/16	1760	1510	1370	1210	1070	930	790
						20-3/16	1	24-3/16	1920	1650	1500	1300	1170	1020	860
						"	2-6 CL	"	2370	2040	1850	1640	1450	1260	1070
						24-3/16	1	28-3/16	2050	1760	1600	1420	1250	1090	920
						"	2-6 CL	"	2500	2150	1950	1730	1530	1330	1130
						"	2-10 CL	"	2630	2260	2050	1820	1600	1390	1180

# STYLES JDVB 14, 20 & 24 DURAVANE II

COPPER/ALUMINUM ELEMENT					ENCLOSURE DEPTH IN INCHES	ENCLOSURE HEIGHT IN INCHES	TIERS AND CENTERS IN INCHES	MTG. HEIGHT IN INCHES	STEAM 215° FACTOR	Hot Water (AVG.)					
TUBE SIZE	CATALOG DESIGNATION	FIN SIZE IN INCHES	FIN/FT	FIN THICKNESS						200°	190°	180°	170°	160°	150°
										Factor					
1"	C43	4-1/4" SQ.	32	0.020"	5-9/16	14-3/16	1	18-3/16	1470	1260	1150	1010	900	780	660
						20-3/16	1	24-3/16	1540	1320	1200	1060	940	820	690
						"	2-6 CL	"	2340	2010	1830	1610	1430	1240	1050
						24-3/16	1	28-3/16	1580	1360	1230	1090	960	840	710
						"	2-6 CL	"	2440	2100	1900	1680	1490	1290	1100
"	"	2-10 CL	"	2490	2140	1940	1720	1520	1320	1120					
1"	C44	4-1/4" SQ.	40	0.020"	5-9/16	14-3/16	1	18-3/16	1720	1480	1340	1190	1050	910	770
						20-3/16	1	24-3/16	1810	1560	1410	1250	1100	960	810
						"	2-6 CL	"	2510	2160	1960	1730	1530	1330	1130
						24-3/16	1	28-3/16	1920	1650	1500	1320	1170	1020	860
						"	2-6 CL	"	2600	2240	2030	1790	1590	1380	1170
"	"	2-10 CL	"	2660	2290	2070	1840	1620	1410	1200					
1"	C45	4-1/4" SQ.	50	0.020"	5-9/16	14-3/16	1	18-3/16	1900	1630	1480	1310	1160	1010	860
						20-3/16	1	24-3/16	2090	1800	1630	1440	1270	1110	940
						"	2-6 CL	"	2510	2160	1960	1730	1530	1330	1130
						24-3/16	1	28-3/16	2250	1940	1760	1550	1370	1190	1010
						"	2-6 CL	"	2710	2330	2110	1870	1650	1440	1220
"	"	2-10 CL	"	2830	2430	2210	1950	1730	1500	1270					
1-1/4"	C143	4-1/4" SQ.	32	0.020"	5-9/16	14-3/16	1	18-3/16	1440	1240	1120	990	880	760	650
						20-3/16	1	24-3/16	1510	1300	1180	1040	920	800	680
						"	2-6 CL	"	2300	1980	1790	1590	1400	1220	1040
						24-3/16	1	28-3/16	1550	1330	1210	1070	950	820	700
						"	2-6 CL	"	2390	2060	1860	1650	1460	1270	1080
"	"	2-10 CL	"	2440	2100	1900	1680	1490	1290	1100					
1-1/4"	C144	4-1/4" SQ.	40	0.020"	5-9/16	14-3/16	1	18-3/16	1690	1450	1320	1170	1030	900	760
						20-3/16	1	24-3/16	1780	1530	1390	1230	1090	940	800
						"	2-6 CL	"	2460	2120	1920	1700	1500	1300	1110
						24-3/16	1	28-3/16	1890	1630	1470	1300	1150	1000	850
						"	2-6 CL	"	2550	2190	1990	1760	1560	1350	1150
"	"	2-10 CL	"	2620	2250	2040	1810	1600	1390	1180					
1-1/4"	C145	4-1/4" SQ.	50	0.020"	5-9/16	14-3/16	1	18-3/16	1870	1610	1460	1290	1140	990	840
						20-3/16	1	24-3/16	2050	1760	1600	1410	1250	1090	920
						"	2-6 CL	"	2460	2120	1920	1700	1500	1300	1110
						24-3/16	*1	28-3/16	2210	1900	1720	1520	1350	1170	990
						"	2-6 CL	"	2650	2280	2070	1830	1620	1400	1190
"	"	2-10 CL	"	2780	2390	2170	1920	1700	1470	1250					

## "B" OFFSET

ELEMENT TUBE SIZE	CRADLE NO.	A MIN	A MAX
3/4 COPPER	2	7 3/8	8 3/4
1" COPPER	2	7 1/2	8 7/8
1 1/4 COPPER	2	7 5/8	9"
1 1/4 STEEL	2	7 7/8	9 1/4
2" STEEL	1	7 5/8	9"

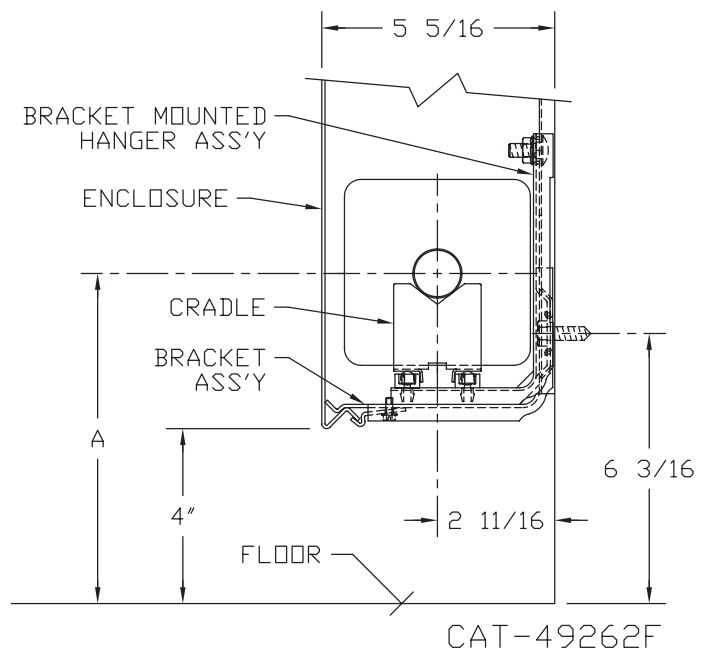

Drawing shows enclosure with steam bracket and bracket mounted hanger.



# STYLES JDVA 14, 20 & 24 DURAVANE II

JDVA 24

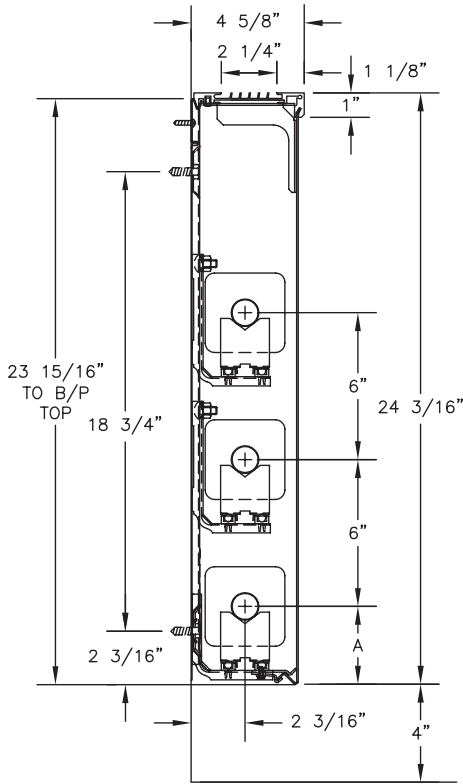

JDVA 20

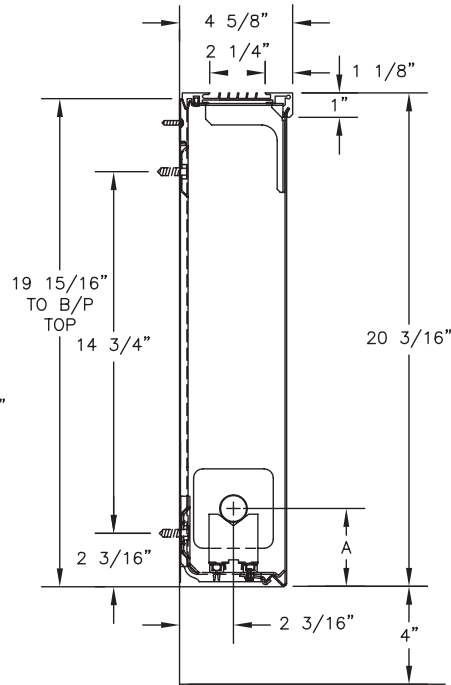

JDVA 14

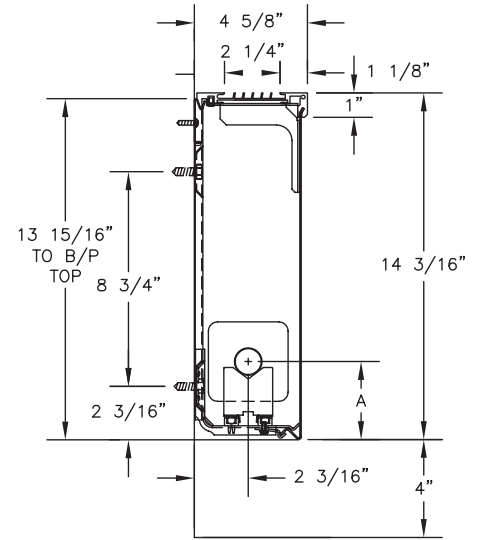

ELEMENT TUBE SIZE	CRADLE NO.	A MIN.
3/4 COPPER	2	3
1' COPPER	2	3 3/16
1 1/4 COPPER	1	2 5/8
1 1/4 STEEL	1	2 13/16

CAT-72727B

STEEL ELEMENT					ENCLOSURE DEPTH IN INCHES	ENCLOSURE HEIGHT IN INCHES	TIERS AND CENTERS IN INCHES	MTG. HEIGHT IN INCHES	STEAM 215° FACTOR	Hot Water (AVG.)					
I.P.S. SIZE	CATALOG DESIGNATION	FIN SIZE IN INCHES	FIN/FT	FIN THICKNESS						200°	190°	180°	170°	160°	150°
										Factor					
1-1/4"	S133	3-1/4" SQ.	32	0.032"	4-5/8	14-3/16	1	18-3/16	1020	0.86	0.78	0.69	0.61	0.53	0.45
						20-3/16	1	24-3/16	1120	960	870	770	680	590	500
						"	2-6 CL	"	1680	1440	1310	1160	1020	890	760
						24-3/16	1	28-3/16	1160	1000	900	800	710	610	520
1-1/4"	S134	3-1/4" SQ.	40	0.032"	4-5/8	14-3/16	1	18-3/16	1110	950	870	770	680	590	500
						20-3/16	1	24-3/16	1290	1100	1010	890	790	680	580
						"	2-6 CL	"	1800	1550	1400	1240	1100	950	810
						24-3/16	1	28-3/16	1330	1140	1040	920	810	700	600
						"	2-6 CL	"	1860	1600	1450	1280	1130	990	840

†NPT threads furnished on steel elements. Please use domestic fittings for proper installation.

# STYLES JDVA 14, 20 & 24 DURAVANE II

COPPER/ALUMINUM ELEMENT					ENCLOSURE DEPTH IN INCHES	ENCLOSURE HEIGHT IN INCHES	TIERS AND CENTERS IN INCHES	MTG. HEIGHT IN INCHES	STEAM 215° FACTOR	Hot Water (AVG.)					
TUBE SIZE	CATALOG DESIGNATION	FIN SIZE IN INCHES	FIN/FT	FIN THICKNESS						200°	190°	180°	170°	160°	150°
										Factor					
3/4"	C3/4-33	3-1/4" SQ.	32	0.020"	4-5/8	14-3/16	1	18-3/16	1050	900	820	720	640	560	470
						20-3/16	1	24-3/16	1110	950	870	770	680	590	500
						"	2-6 CL	"	1660	1430	1290	1150	1010	880	750
						24-3/16	1	28-3/16	1160	1000	900	800	710	610	520
3/4"	C3/4-34	3-1/4" SQ.	40	0.020"	4-5/8	14-3/16	1	18-3/16	1230	1060	960	850	750	650	550
						20-3/16	1	24-3/16	1300	1120	1010	900	790	690	590
						"	2-6 CL	"	1890	1630	1470	1300	1150	1000	850
						24-3/16	1	28-3/16	1390	1200	1080	960	850	740	630
3/4"	C3/4-35	3-1/4" SQ.	50	0.020"	4-5/8	14-3/16	1	18-3/16	1370	1180	1070	950	840	730	620
						20-3/16	1	24-3/16	1460	1260	1140	1010	890	770	660
						"	2-6 CL	"	2040	1750	1590	1410	1240	1080	920
						24-3/16	1	28-3/16	1550	1330	1210	1070	950	820	700
1"	C33	3-1/4" SQ.	32	0.020"	4-5/8	14-3/16	1	18-3/16	1130	970	880	780	690	600	510
						20-3/16	1	24-3/16	1190	1020	930	820	730	630	540
						"	2-6 CL	"	1780	1530	1390	1230	1090	940	800
						24-3/16	1	28-3/16	1250	1080	980	860	760	660	560
1"	C34	3-1/4" SQ.	40	0.020"	4-5/8	14-3/16	1	18-3/16	1270	1090	990	880	770	670	570
						20-3/16	1	24-3/16	1340	1150	1050	920	820	710	600
						"	2-6 CL	"	1940	1670	1510	1340	1180	1030	870
						24-3/16	1	28-3/16	1430	1230	1120	990	870	760	640
1"	C35	3-1/4" SQ.	50	0.020"	4-5/8	14-3/16	1	18-3/16	1320	1140	1030	910	810	700	590
						20-3/16	1	24-3/16	1400	1200	1090	970	850	740	630
						"	2-6 CL	"	1950	1680	1520	1350	1190	1030	880
						24-3/16	1	28-3/16	1490	1280	1160	1030	910	790	670
1-1/4"	C133	3-1/4" SQ.	32	0.020"	4-5/8	14-3/16	1	18-3/16	1130	970	880	780	690	600	510
						20-3/16	1	24-3/16	1190	1020	930	820	730	630	540
						"	2-6 CL	"	1780	1530	1390	1230	1090	940	800
						24-3/16	1	28-3/16	1250	1080	980	860	760	660	560
1-1/4"	C134	3-1/4" SQ.	40	0.020"	4-5/8	14-3/16	1	18-3/16	1250	1080	980	860	760	660	560
						20-3/16	1	24-3/16	1320	1140	1030	910	810	700	590
						"	2-6 CL	"	1920	1650	1500	1320	1170	1020	860
						24-3/16	1	28-3/16	1410	1210	1100	970	860	750	630
1-1/4"	C135	3-1/4" SQ.	50	0.020"	4-5/8	14-3/16	1	18-3/16	1300	1120	1010	900	790	690	590
						20-3/16	1	24-3/16	1390	1200	1080	960	850	740	630
						"	2-6 CL	"	1940	1670	1510	1340	1180	1030	870
						24-3/16	1	28-3/16	1470	1260	1150	1010	900	780	660

## "A" OFFSET

ELEMENT TUBE SIZE	CRADLE NO.	A MIN	A MAX
3/4" COPPER	2	7 3/8	9 5/8
1" COPPER	2	7 1/2	9 3/4
1 1/4" COPPER	2	7 5/8	9 7/8
1 1/4" STEEL	1	7"	9 1/4

Drawing shows enclosure with steam bracket and bracket mounted hanger.

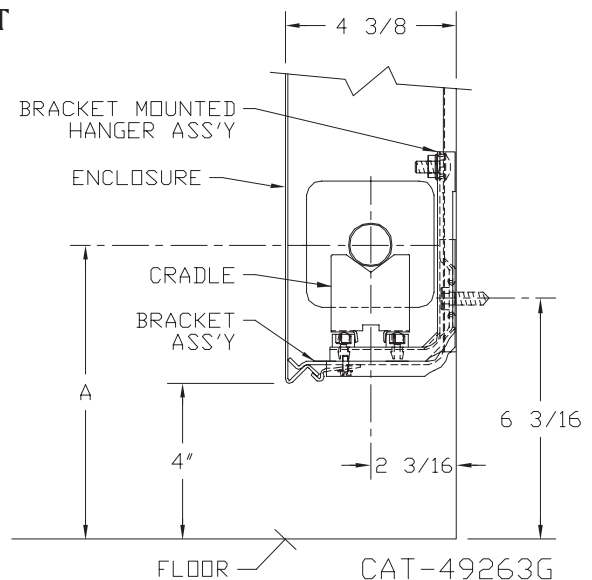



# STYLES JDVA 7 & JDVB 7 DURAVANE II LOW PROFILE

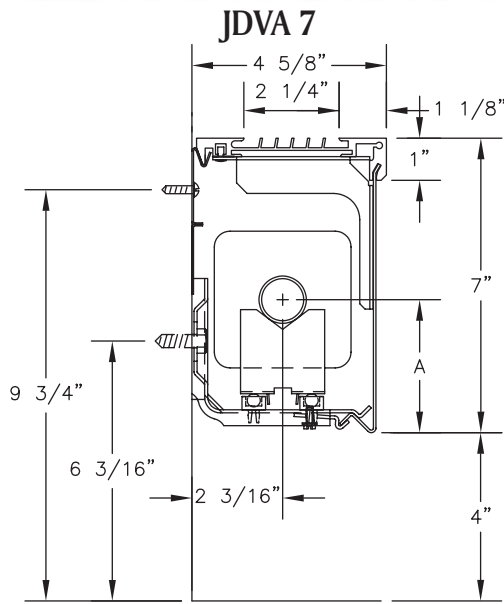

CAT-72728A

ELEMENT TUBE SIZE	CRADLE NO.	A
3/4" COPPER	2	3
1" COPPER	2	3 3/16
1 1/4" COPPER	1	2 5/8
1 1/4" STEEL	1	2 13/16

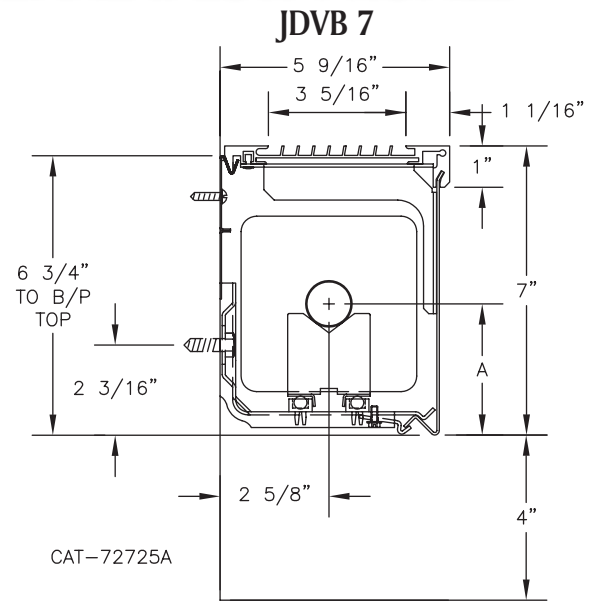

CAT-72725A

ELEMENT TUBE SIZE	CRADLE NO.	A
3/4" COPPER	2	3
1" COPPER	2	3 3/16
1 1/4" COPPER	2	3 5/16
1 1/4" STEEL	2	3 1/2
2" STEEL	1	3 1/4

STEEL ELEMENT					ENCLOSURE DEPTH IN INCHES	ENCLOSURE HEIGHT IN INCHES	TIERS AND CENTERS IN INCHES	MTG. HEIGHT IN INCHES	STEAM 215° FACTOR	Hot Water (AVG.)					
I.P.S. SIZE	CATALOG DESIGNATION	FIN SIZE IN INCHES	FIN/FT	FIN THICKNESS						Factor					
										200°	190°	180°	170°	160°	150°
1-1/4"	†S133	3-1/4" SQ.	32	0.032"	4-5/8	7	1	11	770	660	600	530	470	410	350
1-1/4"	†S134	3-1/4" SQ.	40	0.032"	4-5/8	"	"	"	870	750	680	600	530	460	390
1-1/4"	†S143	4-1/4" SQ.	32	0.032"	5-9/16	"	"	"	1090	940	850	750	660	580	490
1-1/4"	†S144	4-1/4" SQ.	40	0.032"	5-9/16	"	"	"	1210	1040	940	830	740	640	540
2"	†S242	4-1/4" SQ.	25	0.032"	5-9/16	"	"	"	950	820	740	660	580	500	430
2"	†S243	4-1/4" SQ.	32	0.032"	5-9/16	"	"	"	1130	970	880	780	690	600	510

†NPT threads furnished on steel elements. Please use domestic fittings for proper installation.

COPPER/ALUMINUM ELEMENT					ENCLOSURE DEPTH IN INCHES	ENCLOSURE HEIGHT IN INCHES	TIERS AND CENTERS IN INCHES	MTG. HEIGHT IN INCHES	STEAM 215° FACTOR	Hot Water (AVG.)					
TUBE SIZE	CATALOG DESIGNATION	FIN SIZE IN INCHES	FIN/FT	FIN THICKNESS						Factor					
										200°	190°	180°	170°	160°	150°
3/4"	C3/4-34	3-1/4" SQ.	40	0.020"	4-5/8	7	1	11	1000	860	780	690	610	530	450
3/4"	C3/4-35	3-1/4" SQ.	50	0.020"	4-5/8	"	"	"	1010	870	790	700	620	540	450
1"	C33	3-1/4" SQ.	32	0.020"	4-5/8	"	"	"	840	720	660	580	510	450	380
1"	C34	3-1/4" SQ.	40	0.020"	4-5/8	"	"	"	970	830	760	670	590	510	440
1"	C35	3-1/4" SQ.	50	0.020"	4-5/8	"	"	"	980	840	760	680	600	520	440
1-1/4"	C133	3-1/4" SQ.	32	0.020"	4-5/8	"	"	"	810	700	630	560	490	430	360
1-1/4"	C134	3-1/4" SQ.	40	0.020"	4-5/8	"	"	"	930	800	730	640	570	490	420
1-1/4"	C135	3-1/4" SQ.	50	0.020"	4-5/8	"	"	"	940	810	730	650	570	500	420
3/4"	C3/4-434	4-1/4 x 3-5/8	40	0.020"	5-9/16	"	"	"	1240	1070	970	860	760	660	560
3/4"	C3/4-435	4-1/4 x 3-5/8	50	0.020"	5-9/16	"	"	"	1320	1140	1030	910	810	700	590
1"	C433	4-1/4 x 3-5/8	32	0.020"	5-9/16	"	"	"	1150	990	900	790	700	610	520
1"	C434	4-1/4 x 3-5/8	40	0.020"	5-9/16	"	"	"	1260	1080	980	870	770	670	570
1"	C435	4-1/4 x 3-5/8	50	0.020"	5-9/16	"	"	"	1360	1170	1060	940	830	720	610
1-1/4"	C1433	4-1/4 x 3-5/8	32	0.020"	5-9/16	"	"	"	1120	960	870	770	680	590	500
1-1/4"	C1434	4-1/4 x 3-5/8	40	0.020"	5-9/16	"	"	"	1240	1070	970	860	760	660	560
1-1/4"	C1435	4-1/4 x 3-5/8	50	0.020"	5-9/16	"	"	"	1330	1140	1040	920	810	700	600
1"	C43	4-1/4" SQ.	32	0.020"	5-9/16	"	"	"	1260	1080	980	870	770	670	570
1"	C44	4-1/4" SQ.	40	0.020"	5-9/16	"	"	"	1390	1200	1080	960	850	740	630
1"	C45	4-1/4" SQ.	50	0.020"	5-9/16	"	"	"	1410	1210	1100	970	860	750	630
1-1/4"	C143	4-1/4" SQ.	32	0.020"	5-9/16	"	"	"	1230	1060	960	850	750	650	550
1-1/4"	C144	4-1/4" SQ.	40	0.020"	5-9/16	"	"	"	1370	1180	1070	950	840	730	620
1-1/4"	C145	4-1/4" SQ.	50	0.020"	5-9/16	"	"	"	1390	1200	1080	960	850	740	630

# STYLES JDVA & JDVB 10LI DURAVANE II LOUVERED INLET

## JDVA 10LI

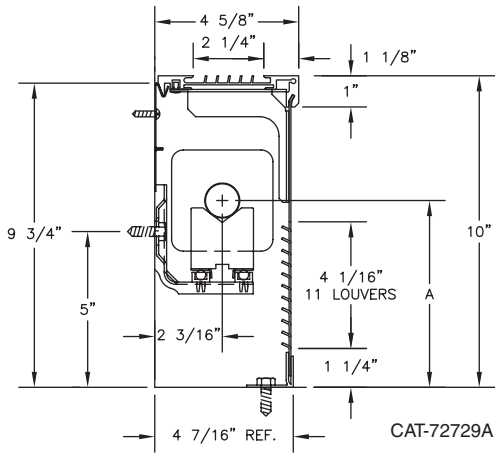

## JDVB 10LI

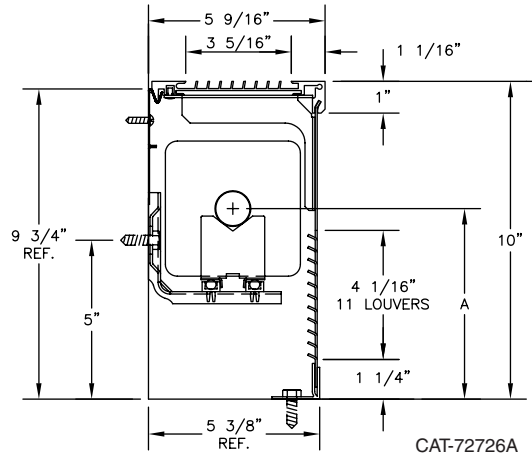

ELEMENT TUBE SIZE	CRADLE NO.	A
3/4 COPPER	2	5 13/16
1" COPPER	2	6"
1 1/4 COPPER	1	5 7/16
1 1/4 STEEL	1	5 5/8

ELEMENT TUBE SIZE	CRADLE NO.	A MAX.
3/4 COPPER	2	5 13/16
1" COPPER	2	6
1 1/4 COPPER	2	6 1/8
1 1/4 STEEL	2	6 5/16
2" STEEL	1	6 1/16

STEEL ELEMENT					ENCLOSURE DEPTH IN INCHES	ENCLOSURE HEIGHT IN INCHES	TIERS AND CENTERS IN INCHES	MTG. HEIGHT IN INCHES	STEAM 215° FACTOR	Hot Water (AVG.)					
I.P.S. SIZE	CATALOG DESIGNATION	FIN SIZE IN INCHES	FIN/FT	FIN THICKNESS						200°	190°	180°	170°	160°	150°
1-1/4"	†S133	3-1/4" SQ.	32	0.032"	4-5/8	10	1	10	730	630	570	510	450	390	330
1-1/4"	†S134	3-1/4" SQ.	40	0.032"	4-5/8	"	"	"	825	720	650	570	510	440	370
1-1/4"	†S143	4-1/4" SQ.	32	0.032"	5-9/16	"	"	"	1035	900	810	720	630	550	470
1-1/4"	†S144	4-1/4" SQ.	40	0.032"	5-9/16	"	"	"	1150	990	900	790	710	610	520
2"	†S242	4-1/4" SQ.	25	0.032"	5-9/16	"	"	"	905	780	710	630	550	480	410
2"	†S243	4-1/4" SQ.	32	0.032"	5-9/16	"	"	"	1075	840	840	740	660	570	490

†NPT threads furnished on steel elements. Please use domestic fittings for proper installation.

COPPER/ALUMINUM ELEMENT					ENCLOSURE DEPTH IN INCHES	ENCLOSURE HEIGHT IN INCHES	TIERS AND CENTERS IN INCHES	MTG. HEIGHT IN INCHES	STEAM 215° FACTOR	Hot Water (AVG.)					
TUBE SIZE	CATALOG DESIGNATION	FIN SIZE IN INCHES	FIN/FT	FIN THICKNESS						200°	190°	180°	170°	160°	150°
3/4"	C3/4-34	3-1/4" SQ.	40	0.020"	4-5/8	10	1	10	950	820	740	655	580	510	430
3/4"	C3/4-35	3-1/4" SQ.	50	0.020"	4-5/8	"	"	"	960	830	750	670	590	510	430
1"	C33	3-1/4" SQ.	32	0.020"	4-5/8	"	"	"	800	690	620	550	490	430	360
1"	C34	3-1/4" SQ.	40	0.020"	4-5/8	"	"	"	920	790	720	640	560	490	420
1"	C35	3-1/4" SQ.	50	0.020"	4-5/8	"	"	"	930	800	720	650	570	500	420
1-1/4"	C133	3-1/4" SQ.	32	0.020"	4-5/8	"	"	"	770	670	600	530	470	410	340
1-1/4"	C134	3-1/4" SQ.	40	0.020"	4-5/8	"	"	"	880	760	700	610	540	470	400
1-1/4"	C135	3-1/4" SQ.	50	0.020"	4-5/8	"	"	"	890	770	710	620	540	480	400
3/4"	C3/4-434	4-1/4 x 3-5/8	40	0.020"	5-9/16	"	"	"	1180	1020	920	820	720	630	530
3/4"	C3/4-435	4-1/4 x 3-5/8	50	0.020"	5-9/16	"	"	"	1255	1090	980	870	770	670	560
1"	C433	4-1/4 x 3-5/8	32	0.020"	5-9/16	"	"	"	1090	940	860	750	670	580	500
1"	C434	4-1/4 x 3-5/8	40	0.020"	5-9/16	"	"	"	1200	1030	930	830	730	640	540
1"	C435	4-1/4 x 3-5/8	50	0.020"	5-9/16	"	"	"	1290	1120	1010	900	790	690	580
1-1/4"	C1433	4-1/4 x 3-5/8	32	0.020"	5-9/16	"	"	"	1070	920	830	730	650	560	480
1-1/4"	C1434	4-1/4 x 3-5/8	40	0.020"	5-9/16	"	"	"	1180	1020	920	820	720	630	530
1-1/4"	C1435	4-1/4 x 3-5/8	50	0.020"	5-9/16	"	"	"	1270	1090	990	880	770	670	570
1"	C43	4-1/4" SQ.	32	0.020"	5-9/16	"	"	"	1200	1030	930	830	730	640	540
1"	C44	4-1/4" SQ.	40	0.020"	5-9/16	"	"	"	1320	1140	1030	910	810	710	600
1"	C45	4-1/4" SQ.	50	0.020"	5-9/16	"	"	"	1340	1150	1050	920	820	720	600
1-1/4"	C143	4-1/4" SQ.	32	0.020"	5-9/16	"	"	"	1170	1010	910	810	710	620	530
1-1/4"	C144	4-1/4" SQ.	40	0.020"	5-9/16	"	"	"	1300	1120	1020	900	800	700	590
1-1/4"	C145	4-1/4" SQ.	50	0.020"	5-9/16	"	"	"	1320	1030	1030	920	810	710	600



# STYLES JDVPB1 & JDVPB2 DURAVANE II

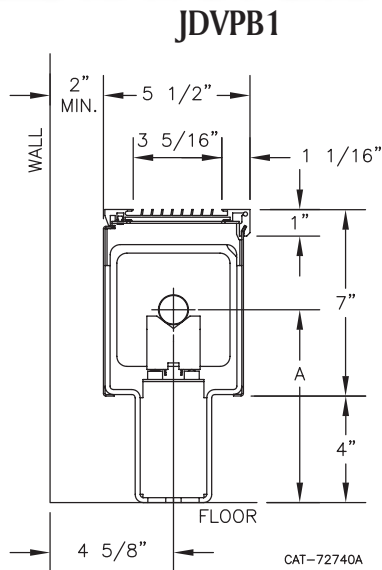

ELEMENT TUBE SIZE	CRADLE NO.	A
3/4" COPPER	2	7 1/16"
1" COPPER	2	7 1/4"
1 1/4" COPPER	2	7 3/8"
1 1/4" STEEL	1	7 9/16"
2" STEEL	1	7 5/16"

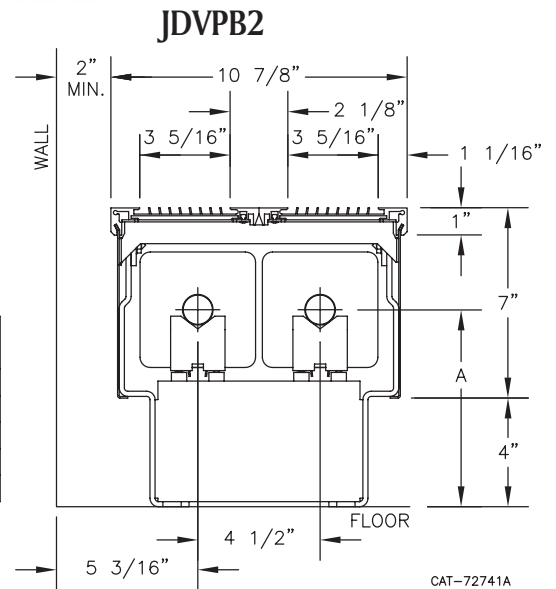

STEEL ELEMENT					ENCLOSURE DEPTH IN INCHES	ENCLOSURE HEIGHT IN INCHES	TIERS AND CENTERS IN INCHES	MTG. HEIGHT IN INCHES	STEAM 215° FACTOR	Hot Water (AVG.)					
I.P.S. SIZE	CATALOG DESIGNATION	FIN SIZE IN INCHES	FIN/FT	FIN THICKNESS						Factor					
										200°	190°	180°	170°	160°	150°
1-1/4"	†S134	4-1/4" SQ.	32	0.032"	5-1/2	7	—	11	1.00	0.86	0.78	0.69	0.61	0.53	0.45
					10-7/8	"	2-W	"	1830	1570	1430	1260	1120	970	830
1-1/4"	†S144	4-1/4" SQ.	40	0.032"	5-1/2	7	—	11	1460	1260	1150	1020	900	780	660
					10-7/8	"	2-W	"	2240	1920	1750	1550	1370	1190	1020
2"	†S242	4-1/4" SQ.	25	0.032"	5-1/2	7	—	11	1160	990	900	800	710	610	520
					10-7/8	"	2-W	"	1590	1370	1240	1100	970	850	720
2"	†S243	4-1/4" SQ.	32	0.032"	5-1/2	7	—	11	1350	1160	1050	930	830	710	600
					10-7/8	"	2-W	"	1840	1580	1440	1270	1120	980	830

- NOTES: 1. These ratings are based on 47°F EAT, to determine ratings with 65°F EAT divide the selected rating by 1.20.  
 2. Steel fin furnished as .032 unless otherwise specified, consult factory.  
 3. NPT threads furnished on steel elements. Please use domestic fittings for proper installation.  
 4. Ratings based on typical window wall installation.  
 5. Not recommended for steam applications.

COPPER/ALUMINUM ELEMENT					ENCLOSURE DEPTH IN INCHES	ENCLOSURE HEIGHT IN INCHES	TIERS AND CENTERS IN INCHES	MTG. HEIGHT IN INCHES	STEAM 215° FACTOR	Hot Water (AVG.)					
TUBE SIZE	CATALOG DESIGNATION	FIN SIZE IN INCHES	FIN/FT	FIN THICKNESS						Factor					
										200°	190°	180°	170°	160°	150°
3/4"	C3/4-434	4-1/4 x 3-5/8	40	0.020"	5-1/2	7	—	11	1400	1200	1100	970	860	740	640
					10-7/8	"	2-W	"	2150	1850	1680	1490	1310	1130	970
3/4"	C3/4-435	4-1/4 x 3-5/8	50	0.020"	5-1/2	7	—	11	1520	1310	1190	1050	930	800	680
					10-7/8	"	2-W	"	2340	2010	1820	1620	1430	1240	1050
1"	C433	4-1/4 x 3-5/8	32	0.020"	5-1/2	7	—	11	1290	1110	1000	890	780	680	580
					10-7/8	"	2-W	"	1990	1710	1560	1380	1220	1060	900
1"	C434	4-1/4 x 3-5/8	40	0.020"	5-1/2	7	—	11	1450	1250	1130	1000	890	770	650
					10-7/8	"	2-W	"	2240	1920	1750	1550	1370	1190	1020
1"	C435	4-1/4 x 3-5/8	50	0.020"	5-1/2	7	—	11	1580	1360	1240	1090	970	840	710
					10-7/8	"	2-W	"	2440	2100	1900	1690	1490	1300	1100
1-1/4"	C1433	4-1/4 x 3-5/8	32	0.020"	5-1/2	7	—	11	1260	1090	980	870	770	670	570
					10-7/8	"	2-W	"	1950	1680	1520	1350	1190	1030	870
1-1/4"	C1434	4-1/4 x 3-5/8	40	0.020"	5-1/2	7	—	11	1430	1230	1110	980	870	760	640
					10-7/8	"	2-W	"	2200	1890	1710	1510	1330	1170	990
1-1/4"	C1435	4-1/4 x 3-5/8	50	0.020"	5-1/2	7	—	11	1560	1350	1220	1070	960	830	700
					10-7/8	"	2-W	"	2400	2070	1860	1650	1460	1270	1070

- NOTES: 1. These ratings are based on 47°F EAT, to determine rating with 65°F EAT divide the selected rating by 1.20.

# STYLES JDVPB1 & JDVPB2 DURAVANE II

## Optional Adjustable Pedestal Bracket Assembly with Aluminum Floor Flange

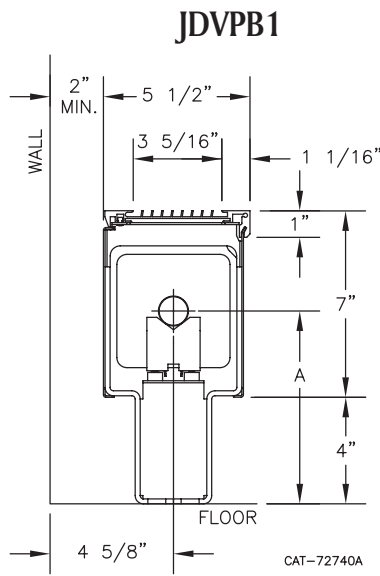

ELEMENT TUBE SIZE	CRADLE NO.	A
3/4" COPPER	2	7 1/16"
1" COPPER	2	7 1/4"
1 1/4" COPPER	2	7 3/8"
1 1/4" STEEL	1	7 9/16"
2" STEEL	1	7 5/16"

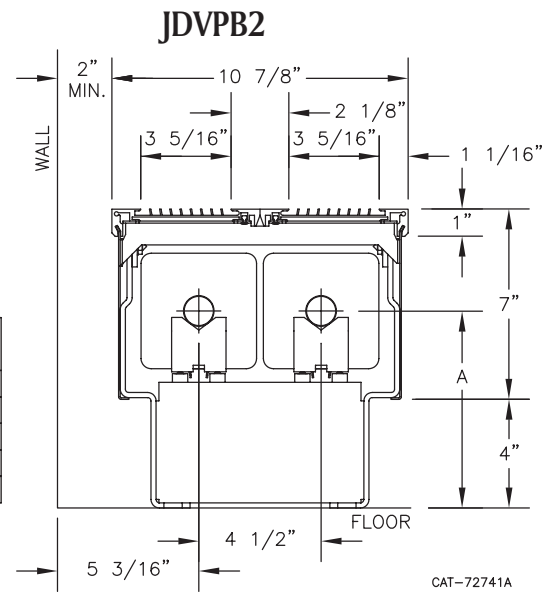

COPPER/ALUMINUM ELEMENT					ENCLOSURE DEPTH IN INCHES	ENCLOSURE HEIGHT IN INCHES	TIERS AND CENTERS IN INCHES	MTG. HEIGHT IN INCHES	STEAM 215° FACTOR	Hot Water (AVG.)					
TUBE SIZE	CATALOG DESIGNATION	FIN SIZE IN INCHES	FIN/FT	FIN THICKNESS						200°	190°	180°	170°	160°	150°
1"	C43	4-1/4" SQ.	32	0.020"	5-1/2	7	—	11	1500	1290	1170	1040	910	790	670
					10-7/8	"	2-W	"	2360	2030	1840	1630	1440	1250	1060
1"	C44	4-1/4" SQ.	40	0.020"	5-1/2	7	—	11	1700	1460	1320	1170	1040	900	770
					10-7/8	"	2-W	"	2890	2490	2250	1990	1760	1530	1300
1"	C45	4-1/4" SQ.	50	0.020"	5-1/2	7	—	11	1750	1500	1360	1200	1060	920	790
					10-7/8	"	2-W	"	3000	2570	2340	2070	1830	1590	1350
1-1/4"	C143	4-1/4" SQ.	32	0.020"	5-1/2	7	—	11	1230	1050	960	850	740	650	560
					10-7/8	"	2-W	"	2370	2040	1850	1640	1450	1260	1060
1-1/4"	C144	4-1/4" SQ.	40	0.020"	5-1/2	7	—	11	1580	1360	1240	1090	970	840	710
					10-7/8	"	2-W	"	2700	2330	2110	1860	1650	1430	1220
1-1/4"	C145	4-1/4" SQ.	50	0.020"	5-1/2	7	—	11	1740	1490	1360	1190	1060	920	780
					10-7/8	"	2-W	"	2990	2570	2330	2070	1820	1580	1350

- NOTES: 1. These ratings are based on 47°F EAT, to determine ratings with 65°F EAT divide the selected rating by 1.20.  
 2. Steel fin furnished as .032 unless otherwise specified, consult factory.  
 3. NPT threads furnished on steel elements. Please use domestic fittings for proper installation.  
 4. Ratings based on typical window wall installation.  
 5. Not recommended for steam applications.

# STYLES JDVPA1 & JDVPA2 DURAVANE II PEDESTAL

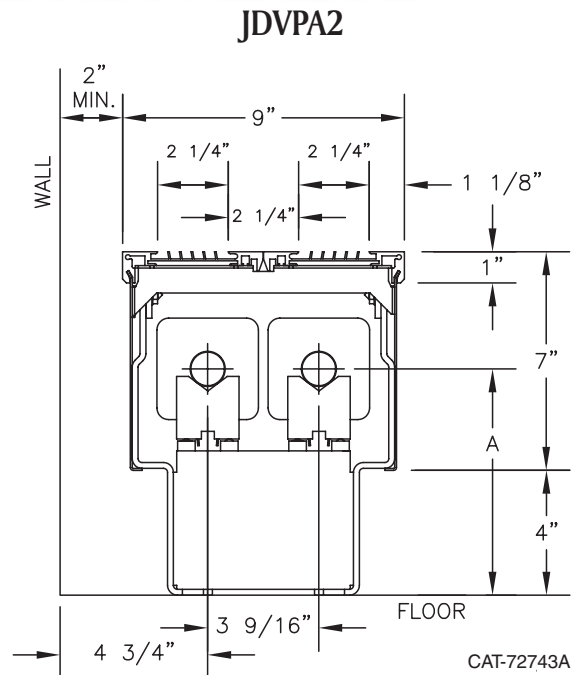
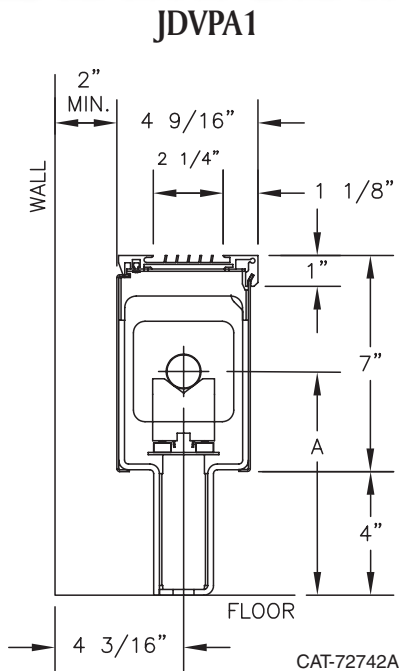

ELEMENT TUBE SIZE	CRADLE NO.	A
3/4" COPPER	2	7 1/16"
1" COPPER	2	7 1/4"
1 1/4" COPPER	2	7 3/8"
1 1/4" STEEL	1	7 9/16"

STEEL ELEMENT					ENCLOSURE DEPTH IN INCHES	ENCLOSURE HEIGHT IN INCHES	TIERS AND CENTERS IN INCHES	MTG. HEIGHT IN INCHES	STEAM 215° FACTOR	Hot Water (AVG.)					
I.P.S. SIZE	CATALOG DESIGNATION	FIN SIZE IN INCHES	FIN/FT	FIN THICKNESS						200°	190°	180°	170°	160°	150°
1-1/4"	S133	3-1/4" SQ.	32	0.032"	4-9/16	7	1	11	920	0.86	0.78	0.69	0.61	0.53	0.45
					9	"	2-W	"	1270	1090	990	880	770	670	570
1-1/4"	S134	3-1/4" SQ.	40	0.032"	4-9/16	7	1	11	1020	880	800	700	620	540	460
					9	"	2-W	"	1400	1200	1090	970	850	740	630

- NOTES: 1. These ratings are based on 47°F EAT, to determine ratings with 65°F EAT divide the selected rating and divide by 1.20.  
 2. Steel fin furnished as .032 unless otherwise specified, consult factory.  
 3. NPT threads furnished on steel elements. Please use domestic fittings for proper installation.  
 4. Ratings based on typical window wall installation.  
 5. Not recommended for steam applications.

COPPER/ALUMINUM ELEMENT					ENCLOSURE DEPTH IN INCHES	ENCLOSURE HEIGHT IN INCHES	TIERS AND CENTERS IN INCHES	MTG. HEIGHT IN INCHES	STEAM 215° FACTOR	Hot Water (AVG.)					
TUBE SIZE	CATALOG DESIGNATION	FIN SIZE IN INCHES	FIN/FT	FIN THICKNESS						200°	190°	180°	170°	160°	150°
3/4"	C3/4-33	3-1/4" SQ.	32	0.020"	4-9/16	7	1	11	990	0.86	0.78	0.69	0.61	0.53	0.45
					9	"	2-W	"	1360	1170	1060	940	830	720	610
3/4"	C3/4-34	3-1/4" SQ.	40	0.020"	4-9/16	7	1	11	1160	1000	900	800	710	610	520
					9	"	2-W	"	1690	1450	1320	1170	1030	900	760
3/4"	C3/4-35	3-1/4" SQ.	50	0.020"	4-9/16	7	1	11	1260	1080	980	870	770	670	570
					9	"	2-W	"	1730	1490	1350	1190	1060	920	780
1"	C33	3-1/4" SQ.	32	0.020"	4-9/16	7	1	11	990	850	770	680	600	520	450
					9	"	2-W	"	1360	1170	1060	940	830	720	610
1"	C34	3-1/4" SQ.	40	0.020"	4-9/16	7	1	11	1200	1030	940	830	730	640	540
					9	"	2-W	"	1650	1420	1290	1140	1010	870	740
1"	C35	3-1/4" SQ.	50	0.020"	4-9/16	7	1	11	1230	1060	960	850	750	650	550
					9	"	2-W	"	1690	1450	1320	1170	1030	900	760
1-1/4"	C133	3-1/4" SQ.	32	0.020"	4-9/16	7	1	11	990	850	770	680	600	520	450
					9	"	2-W	"	1360	1170	1060	940	830	720	610
1-1/4"	C134	3-1/4" SQ.	40	0.020"	4-9/16	7	1	11	1080	930	840	750	660	570	490
					9	"	2-W	"	1490	1280	1160	1030	910	790	670
1-1/4"	C135	3-1/4" SQ.	50	0.020"	4-9/16	7	1	11	1190	1020	930	820	730	630	540
					9	"	2-W	"	1640	1410	1280	1130	1000	870	740

- NOTES: 1. These ratings are based on 47°F EAT, to determine rating with 65°F EAT divide the selected rating by 1.20.

# STYLES JDVPA1 & JDVPA2 DURAVANE II PEDESTAL

Optional Adjustable Pedestal Bracket Assembly with Aluminum Floor Flange

**JDVPA1**  
Adjustable Pedestal Brk't

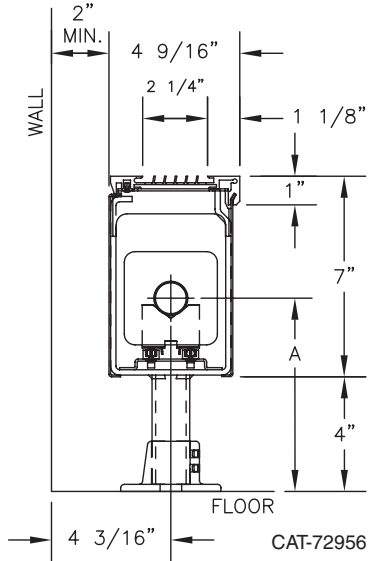

**JDVPA2**  
Adjustable Pedestal Brk't

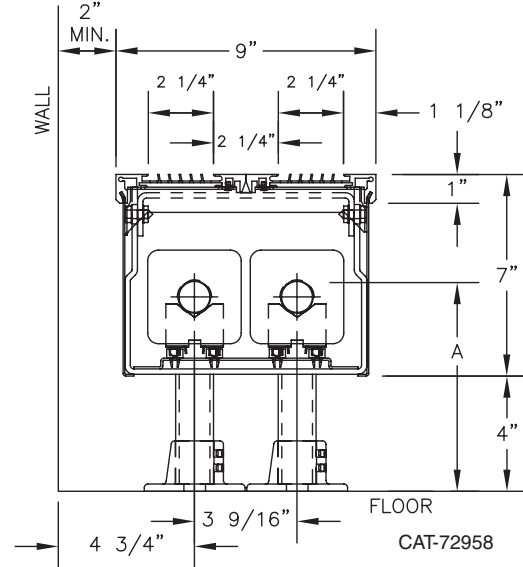

ELEMENT TUBE SIZE	CRADLE NO.	A
3/4" COPPER	2	7 1/16"
1" COPPER	2	7 1/4"
1 1/4" COPPER	2	7 3/8"
1 1/4" STEEL	1	7 9/16"

**JDVPB1**  
Adjustable Pedestal Brk't

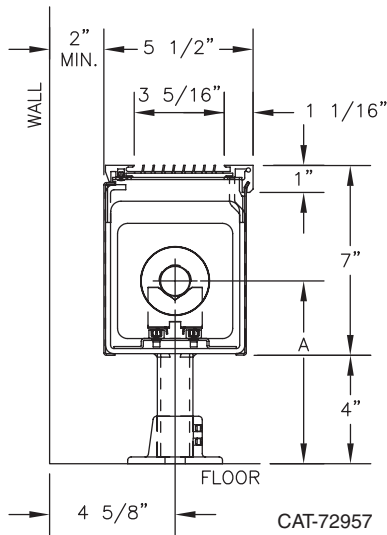

**JDVPB2**  
Adjustable Pedestal Brk't

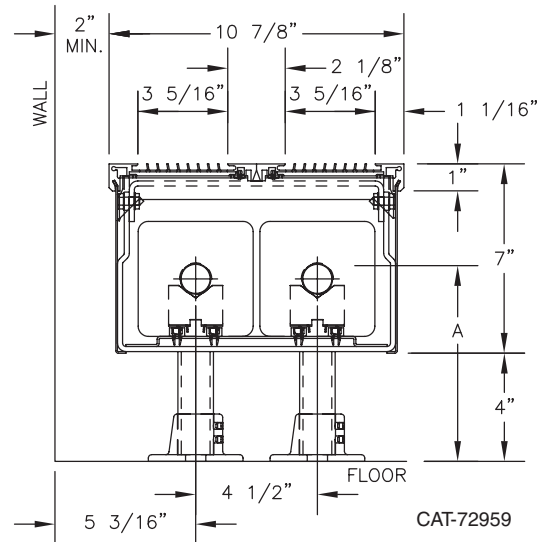

ELEMENT TUBE SIZE	CRADLE NO.	A
3/4" COPPER	2	7 1/16"
1" COPPER	2	7 1/4"
1 1/4" COPPER	2	7 3/8"
1 1/4" STEEL	1	7 9/16"
2" STEEL	1	7 5/16"



# DURAVANE II ACCESSORIES

Overlapping Accessories (allow for wall-length variation when running corner-to-corner).

Dura-Vane II wall mounted enclosure accessories fit securely with no visible fasteners. All are flanged for rigidity, overlap the backplate and have bendable tabs at the bottom to secure the accessory to the enclosure.

Dura-Vane II JDVA 10LI and JVDB 10LI wall mounted enclosure accessories fit securely and use visible bottom fasteners in lieu of tabs. All are flanged for rigidity and overlap the back plate.

Wall sleeves are intended to extend to the wall. End caps are placed at the end where the enclosure does not terminate at wall. Inside and outside corners have a solid top. Special angle corners (other than 90 and 135 degrees) are also available.

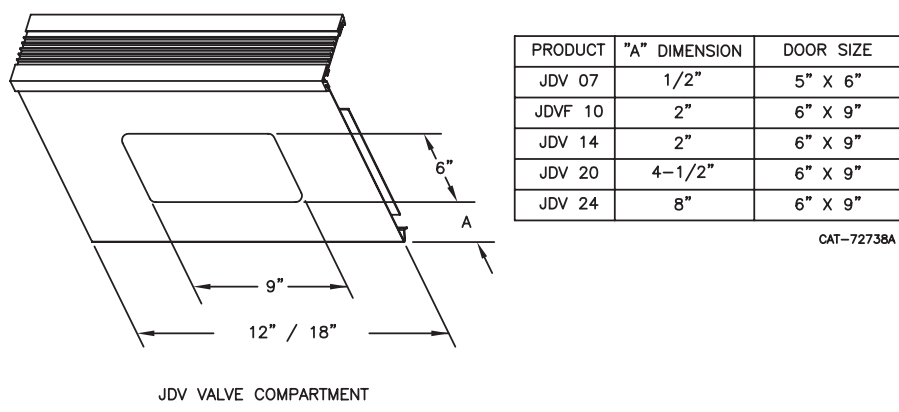
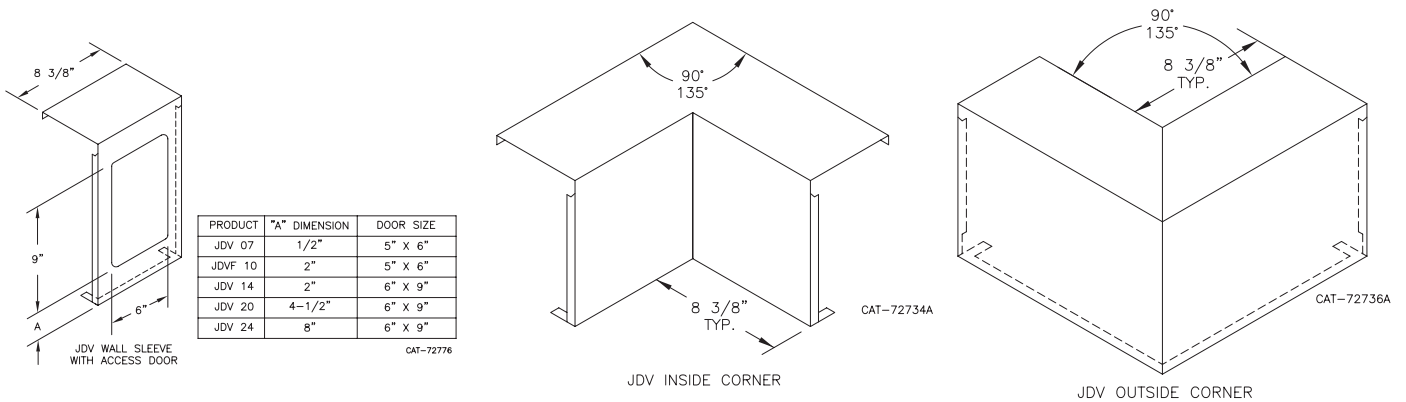
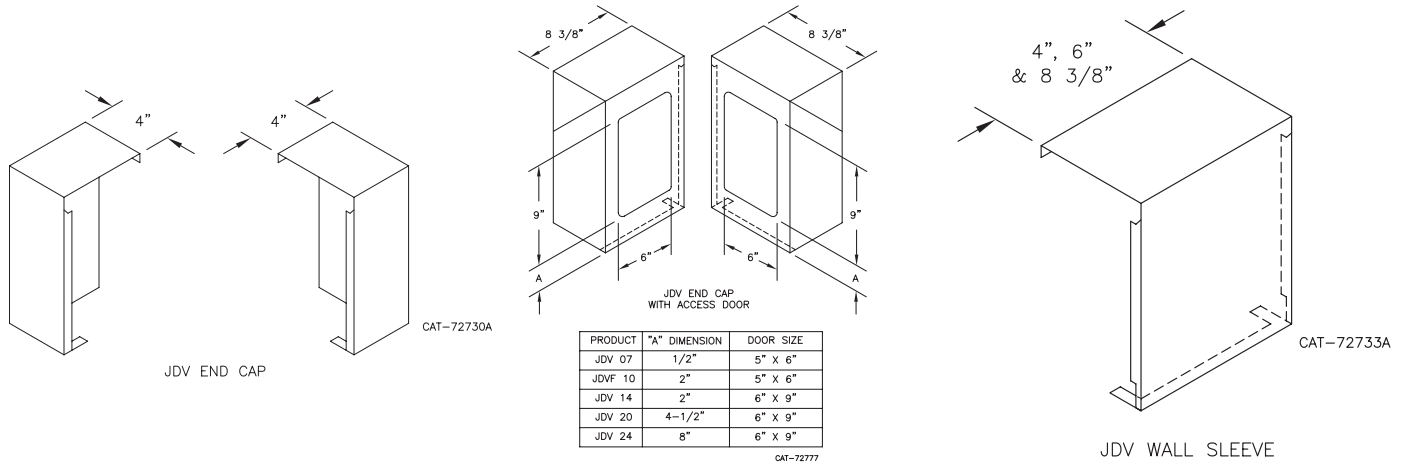

# ACCESSORIES

## STYLES JDVA & JDVB WALL MOUNTED INSTALLATION AND ACCESSORY DETAILS

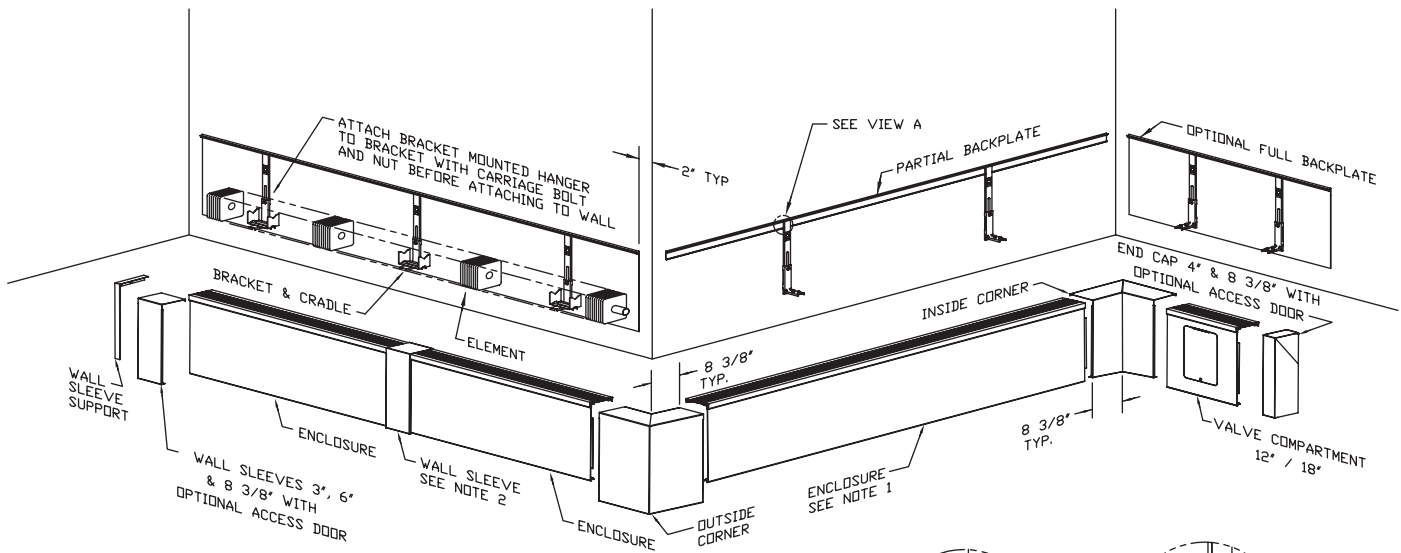

**NOTES:**

1. ENCLOSURE SECTIONS AVAILABLE IN FOLLOWING STANDARD LENGTHS: 1' THRU 8' IN 6" INCREMENTS. CONSULT FACTORY FOR SPECIAL LENGTHS.
2. WALL SLEEVES MAY BE AT ENDS OR PLACED IN RUN FOR DIMENSIONAL MAKE-UP.

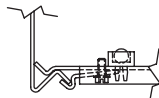

ENCLOSURE AND BRACKET ASS'Y

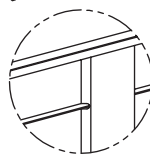

VIEW A

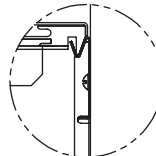

TOP OF ACCESSORY INSTALLED AT WALL

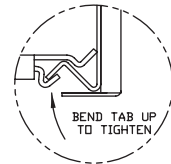

BOTTOM OF ACCESSORY INSTALLED AT ENCLOSURE BOTTOM



TYPICAL ENCLOSURE SLIP JOINT

CAT-72739A

## STYLES JDVA 10LI & JDVB 10LI WALL MOUNTED INSTALLATION AND ACCESSORY DETAILS

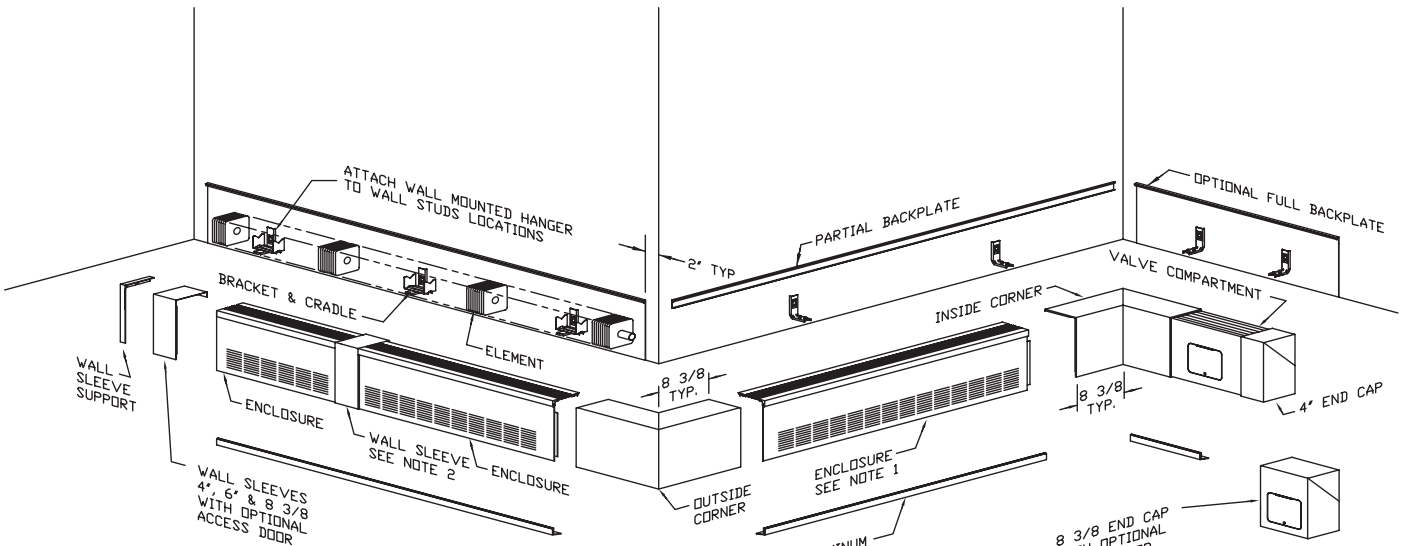

**NOTES:**

1. ENCLOSURE SECTIONS AVAILABLE IN FOLLOWING STANDARD LENGTHS: 1' THRU 8' IN 6" INCREMENTS. CONSULT FACTORY FOR SPECIAL LENGTHS.
2. WALL SLEEVES MAY BE AT ENDS OR PLACED IN RUN FOR DIMENSIONAL MAKE-UP.

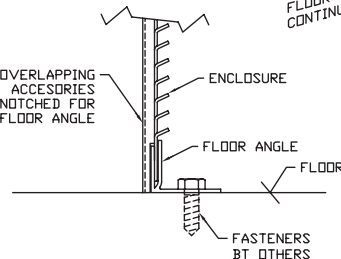

EXTRUDED ALUMINUM FLOOR ANGLE TO BE CONTINUOUS

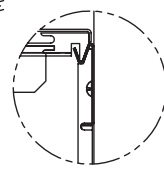

TOP OF ACCESSORY INSTALLED AT WALL

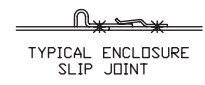

TYPICAL ENCLOSURE SLIP JOINT

CAT-72783

# ACCESSORIES

## STYLES JDVA 07 & JDVB 07 WALL MOUNTED INSTALLATION AND ACCESSORY DETAILS

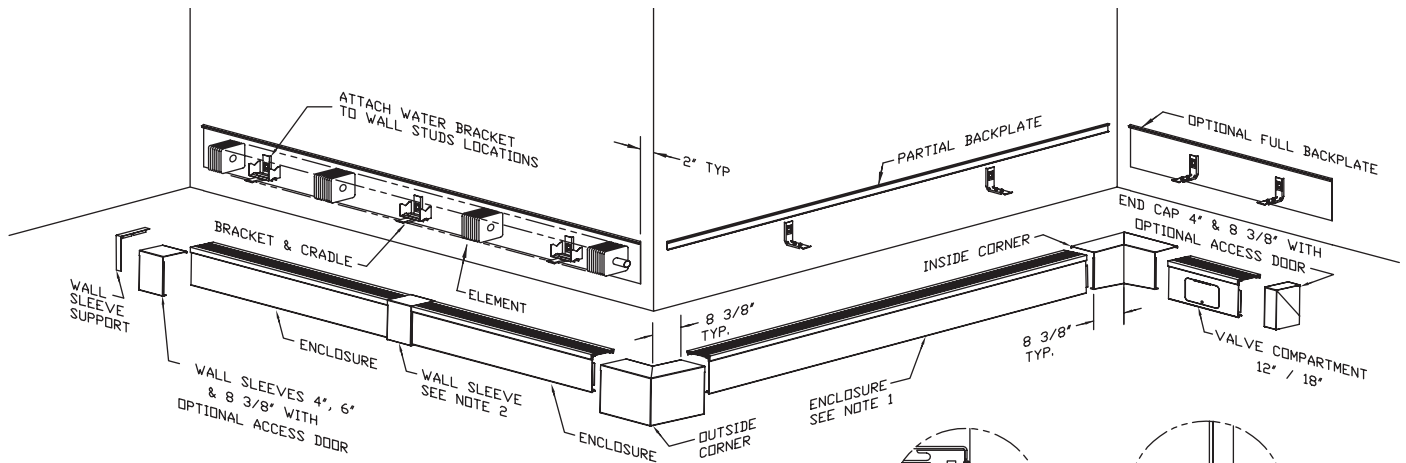

**NOTES:**

1. ENCLOSURE SECTIONS AVAILABLE IN FOLLOWING STANDARD LENGTHS: 1' THRU 8' IN 6" INCREMENTS. CONSULT FACTORY FOR SPECIAL LENGTHS.
2. WALL SLEEVES MAY BE AT ENDS OR PLACED IN RUN FOR DIMENSIONAL MAKE-UP.

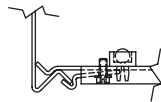

ENCLOSURE AND BRACKET ASS'Y

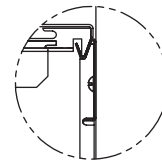

TOP OF ACCESSORY INSTALLED AT WALL

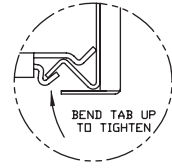

BOTTOM OF ACCESSORY INSTALLED AT ENCLOSURE BOTTOM  
BEND TAB UP TO TIGHTEN



TYPICAL ENCLOSURE SLIP JOINT

CAT-72782

# ACCESSORIES

## STYLES JDVP A1/A2 & JDVP B1/B2 PEDESTAL MOUNTED INSTALLATION AND ACCESSORY DETAILS

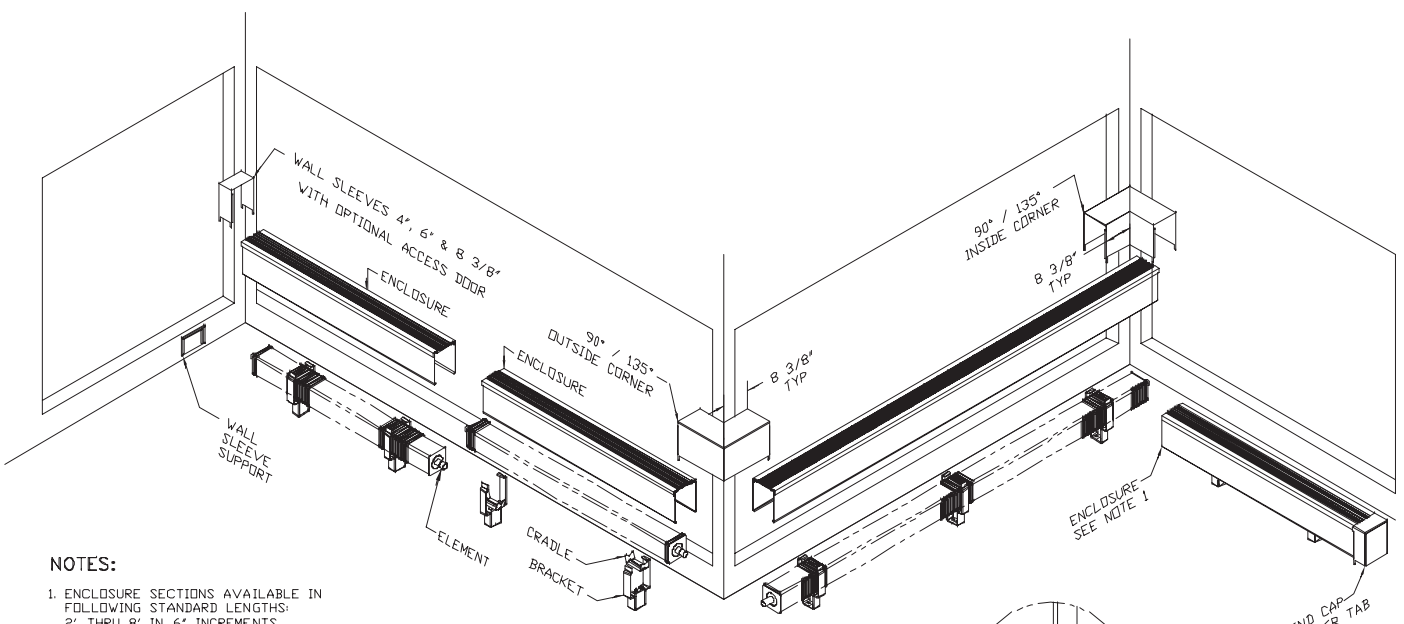
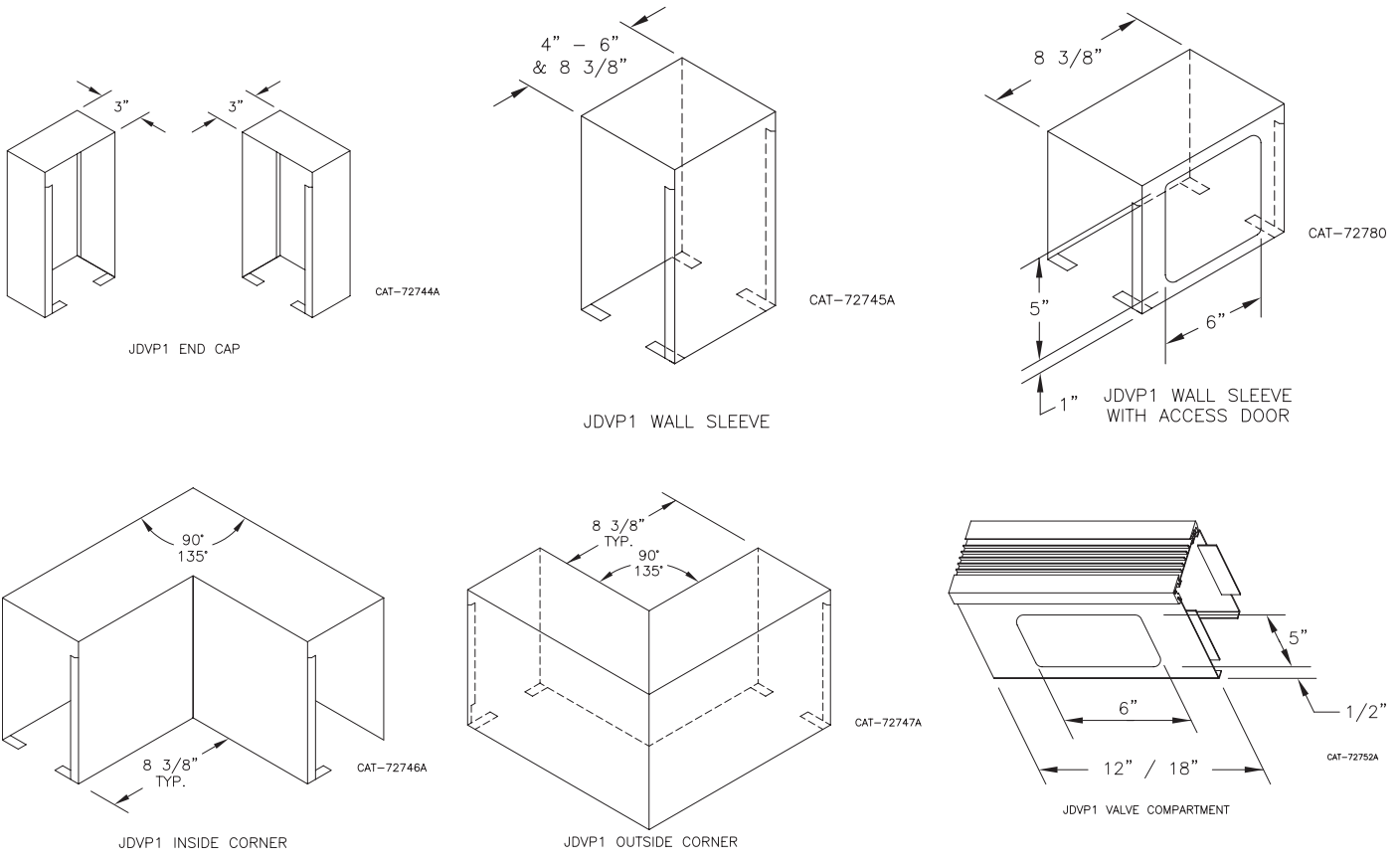

**NOTES:**

- ENCLOSURE SECTIONS AVAILABLE IN FOLLOWING STANDARD LENGTHS: 2' THRU 8' IN 6" INCREMENTS. CONSULT FACTORY FOR SPECIAL LENGTHS.
- LAYOUT JOB SELECTING ENCLOSURE LENGTHS WITH SLIP JOINT AT EACH END OF ENCLOSURE. SPACE ENCLOSURES TO SUIT. AT EACH END OF RUN USE WALL SLEEVE OR 3" END TO SUIT JOB.
- LAY OUT PEDESTAL BRACKET LOCATIONS SO THE BRACKETS ARE 6" TO 12" FROM THE END OF ENCLOSURE. FOR ENCLOSURES OVER 5 FT LONG, LOCATE AN ADDITIONAL BRACKET AT THE CENTER OF THAT ENCLOSURE.
- SCHEDULE ACCESSORIES TO OVERLAP ENCLOSURES 1'-3" EXCEPT ENDS 1'-2". WITH ACCESS DOOR OVERLAP MAX. 1".

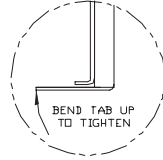

BOTTOM OF ACCESSORY INSTALLED AT ENCLOSURE BOTTOM

CAT-72754A



# DESIGN DATA

## COMMERCIAL FINNED TUBE CHARTS FOR RATING CORRECTIONS

Catalog finned tube ratings are based upon the following conditions:

- Steam ratings are based on .899 pounds of steam @ 215°F and 65°F entering air temperature at sea level.
- Water ratings shown are based on 3 Ft/sec. velocity and have been determined by applying correction factors developed by I=B=R to the steam ratings. For velocities less than 3 Ft/sec., see chart below for applicable correction factors.
- Ratings are based on active (finned) length. Steel element fins have black enamel finish.
- Ratings are based on mounting heights indicated in tables shown.

Use the following calculation with correction factors for job conditions to determine corrected rating:

$$\text{Corrected Rating} = (215^\circ\text{f Catalog Rating}) \times \left( \begin{array}{c} \text{Correction Factor For} \\ \text{Steam Or Water And} \\ \text{Average Air Temp.} \end{array} \right) \times \left( \begin{array}{c} \text{Correction Factor} \\ \text{For Flow Rate} \end{array} \right) \times \left( \begin{array}{c} \text{Correction For Mounting} \\ \text{Hgt. See Catalog Rating} \end{array} \right)$$

WATER VELOCITY (Ft./sec.)	IBR CORRECTION FACTOR
0.25	.905
0.50	.931
1.00	.957
1.50	.973
2.00	.984
2.50	.992
3.00 or more	1.000

Use The Following Charts To Select Correction Factors

CHART/WATER VEL./CORR. FACTOR / PRESS. DROP/TOTAL BTU.

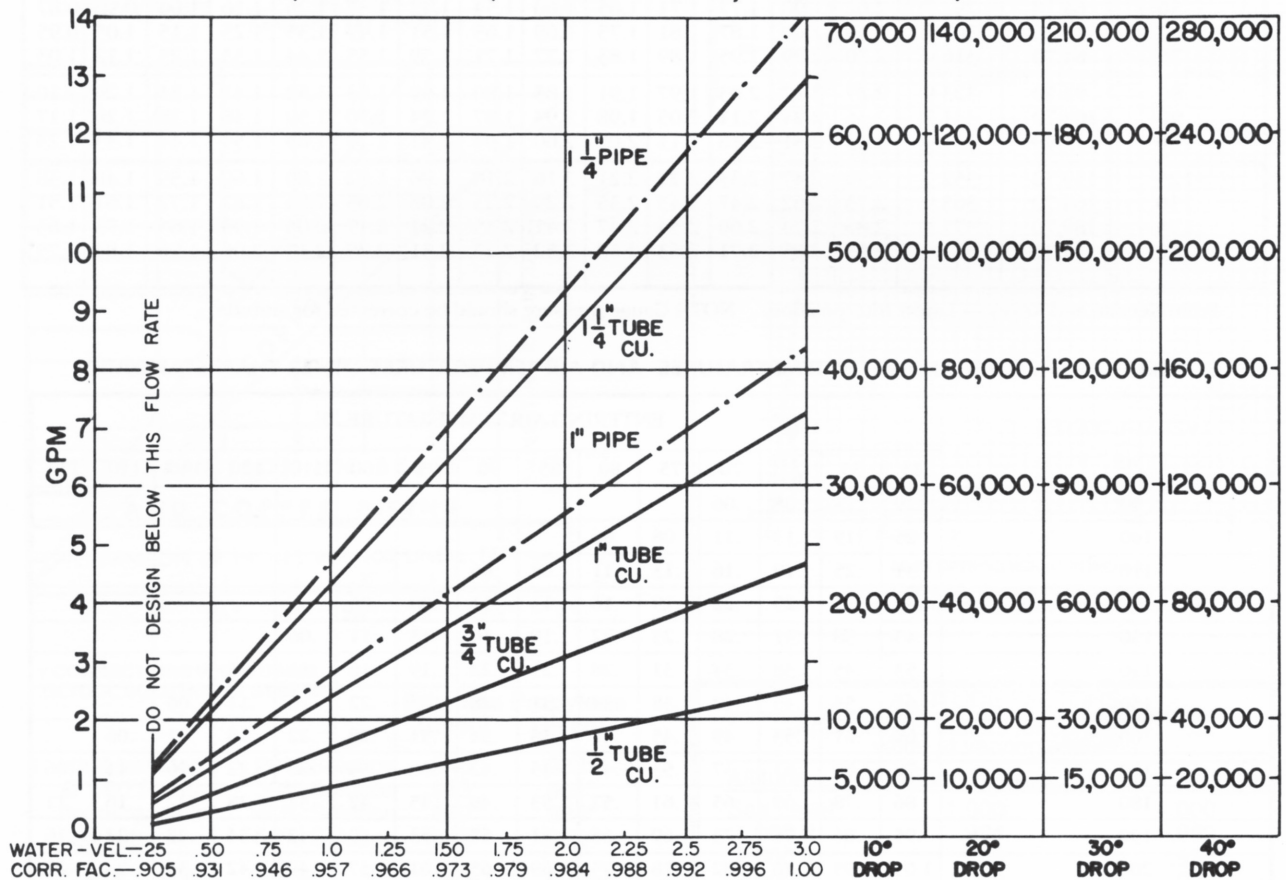

1/2" COP ALUM.	1,80	2,33	5,33	9,16				
3/4" COP ALUM.	.5	1,5	3,16	5,4	6,25			
1" COP ALUM.	.233	.41	.83	1,45	2,16	2,83	3,66	
1" PIPE	.37	.79	1,3	2,00	2,70	3,70	4,80	
1 1/4" COP ALUM.	.16	.33	.55	.79	1,08	1,33	1,8	2,25
1 1/4" PIPE	.09	.18	.31	.5	.70	1,0	1,1	1,3

PRESSURE DROP PER 100 LINEAR FT., IN FEET OF HEAD

STANDARD RATE OF PITCH = 1/2" FOR 20' OR RUN

# DESIGN DATA

## GUARANTEED WORKING PRESSURES

- 1" IPS — 780 at Temperatures up to 650°F
- 1-1/4" IPS — 660 at Temperatures up to 650°F
- 2" IPS — 405 at Temperatures up to 650°F
- 1-1/4" CU — 194 at Temperatures up to 300°F
- 1" CU 204 at Temperatures up to 300°F
- 3/4" CU 218 PSI at Temperatures up to 300°F

MAXIMUM PRESSURES AT OTHER TEMPERATURES  
ARE AVAILABLE UPON REQUEST.

### PIPE WATER CAPACITIES AND QUANTITIES CIRCULATED AT VELOCITY OF 3\* FEET PER SECOND

PIPE SIZE	GALS. PER LINEAR FT.	GALS./MIN. @ 3' SEC. VEL.*	LBS./HR. @ 3' SEC. VEL.*
1/2"	.016	2.88	1440
3/4"	.023	4.14	2070
1"	.040	7.20	3600
1-1/4"	.063	11.34	5660
1-1/2"	.102	18.36	9160
2"	.170	30.60	15300
2-1/2"	.275	49.50	24850
3"	.390	70.20	35000

\*3 Ft./Sec. Velocity is Basis for Hot Water Rating Factors Shown on this Page.

$$\text{VELOCITY FT./SEC.} = \frac{\text{LBS. PER HOUR}}{(\text{GALS. PER FT.}) (3600) (8.3)}$$

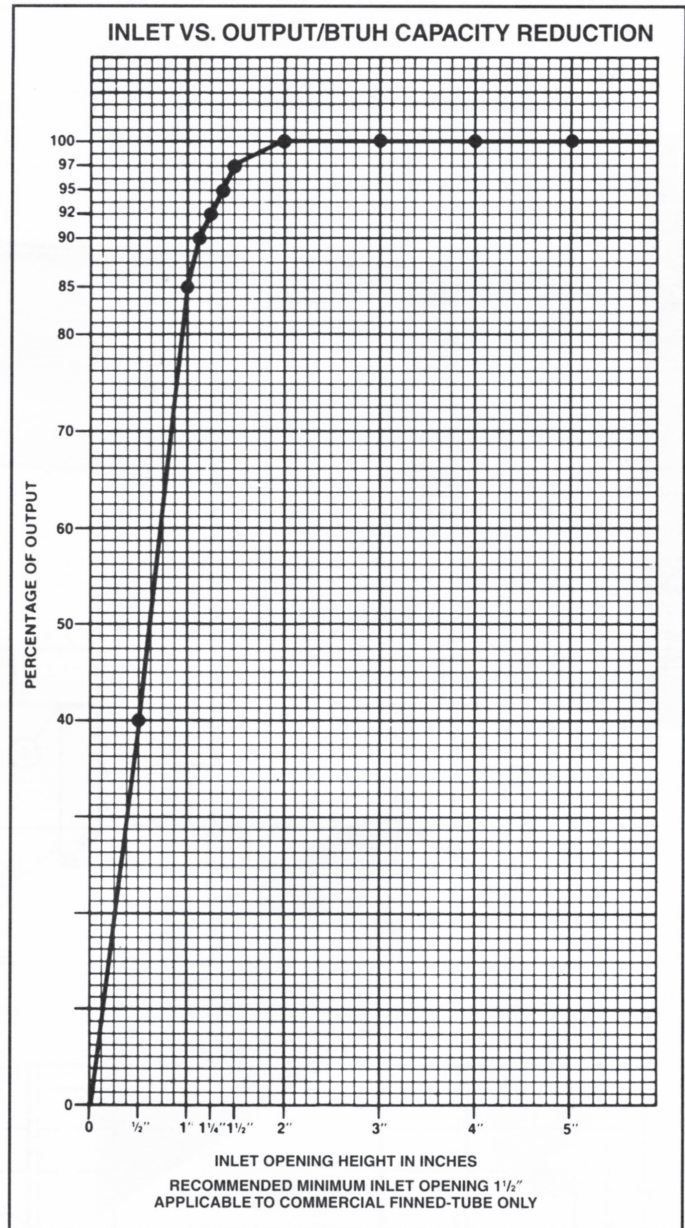
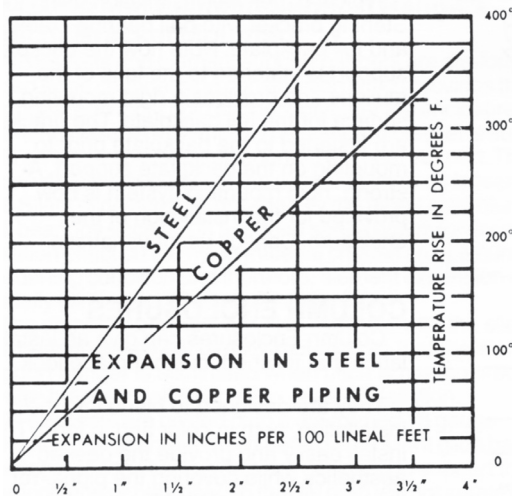

### † CORRECTIONS WHEN USING GLYCOL SOLUTION IN SYSTEM

		ETHYLENE GLYCOL		PROPYLENE GLYCOL	
1. Heat transfer @ 180°F, with no increase in flow rate	20% Solution	.946*	.982*		
	30% Solution	.913*	.961*		
	40% Solution	.879*	.934*		
	50% Solution	.842*	.902*		
2. G.P.M. Req'd. @ 180°F, (No correction to pump curve)	20° Δt	114%*	110%*		
3. Pump head req'd. @ 180°F, with increase in G.P.M.		123%*	123%*		
4. Freezing Point	50% by volume	-37°F	-28°F		
	40%	-14°F	-13°F		
	30%	+ 2°F	+ 4°F		
	20%	+15°F	+17°F		

\*Compared To Water.

### ALTITUDE FACTORS

Approximate factors for convective heat value at varying altitudes

Altitude	Ferrous Units	Copper Alum. Units
Sea Level	1.000	1,000
1,000 ft.	.984	.969
2,000 ft.	.968	.938
3,000 ft.	.952	.908
4,000 ft.	.936	.878
5,000 ft.	.920	.850
6,000 ft.	.904	.822
7,000 ft.	.889	.795
8,000 ft.	.874	.768
9,000 ft.	.859	.743
10,000 ft.	.844	.718
15,000 ft.	.771	.603
20,000 ft.	.703	.502

† Note: The heat output of standard heat distributing units is not affected enough to be considered in sizing the units, when the flow rate has been increased as shown at left. If not increased, apply appropriate heat transfer correction factor indicated.

# DESIGN DATA

CORRECTION FACTORS FOR STEAM PRESSURES AND AIR TEMPERATURES OTHER THAN STANDARD																
STEAM		ENTERING AIR TEMPERATURE °F														
PRESSURE		TEMP. °F	45	55	STD 65	70	75	80	85	90	100	110	120	130	140	150
GAUGE	ABS. PSI															
(VAC) 15" HG	7.32	178.9	0.90	0.80	0.70	0.65	0.60	0.56	0.51	0.45	0.39	0.32	0.25	0.18	0.13	0.08
(VAC) 10"	9.78	192.2	1.02	0.91	0.81	0.76	0.71	0.66	0.62	0.55	0.48	0.40	0.33	0.26	0.20	0.14
(VAC) 5"	12.25	202.9	1.11	1.00	0.90	0.85	0.79	0.75	0.70	0.63	0.56	0.48	0.40	0.33	0.27	0.20
▶ 0 PSI	14.696	212.0	1.19	1.09	0.97	0.92	0.87	0.82	0.77	0.70	0.63	0.54	0.46	0.38	0.31	0.25
	.899	15.595	1.22	1.11	1.00	0.95	0.90	0.84	0.80	0.75	0.65	0.57	0.48	0.40	0.33	0.26
	5	19.70	227.1	1.34	1.22	1.11	1.05	1.00	0.95	0.90	0.81	0.75	0.66	0.57	0.49	0.41
10	24.70	239.4	1.45	1.33	1.22	1.17	1.11	1.05	1.00	0.91	0.85	0.75	0.66	0.58	0.50	0.42
15	29.70	249.8	1.55	1.43	1.31	1.26	1.20	1.14	1.09	1.00	0.94	0.84	0.75	0.66	0.57	0.49
20	34.70	258.5	1.63	1.52	1.40	1.33	1.28	1.23	1.17	1.07	1.02	0.92	0.82	0.73	0.64	0.55
25	39.70	266.8	1.71	1.59	1.47	1.41	1.36	1.30	1.25	1.15	1.09	0.98	0.89	0.80	0.71	0.62
30	44.70	274.0	1.78	1.66	1.54	1.48	1.42	1.37	1.31	1.21	1.15	1.05	0.95	0.85	0.76	0.68
40	54.70	286.7	1.91	1.79	1.66	1.61	1.54	1.49	1.43	1.32	1.27	1.16	1.06	0.97	0.87	0.78
50	64.70	297.7	2.02	1.90	1.77	1.71	1.65	1.60	1.54	1.42	1.37	1.26	1.16	1.06	0.96	0.87
60	74.70	307.3	2.10	2.00	1.87	1.81	1.75	1.69	1.63	1.51	1.47	1.35	1.25	1.15	1.05	0.95
70	84.70	316.0	2.20	2.09	1.95	1.89	1.83	1.77	1.71	1.59	1.55	1.44	1.33	1.23	1.12	1.03
80	94.70	323.9	2.27	2.17	2.03	1.97	1.91	1.85	1.80	1.69	1.63	1.52	1.41	1.31	1.20	1.10
90	104.70	331.2	2.36	2.24	2.11	2.05	1.98	1.93	1.87	1.74	1.70	1.59	1.48	1.38	1.28	1.17
100	114.70	337.9	2.43	2.31	2.18	2.11	2.05	2.00	1.94	1.81	1.77	1.65	1.54	1.44	1.33	1.23
125	139.70	352.9	2.59	2.47	2.33	2.27	2.21	2.16	2.10	1.96	1.92	1.80	1.69	1.59	1.48	1.38
150	164.70	365.9	2.73	2.62	2.47	2.43	2.35	2.29	2.23	2.08	2.05	1.94	1.82	1.72	1.61	1.51
175	189.70	377.4	2.86	2.74	2.60	2.54	2.47	2.41	2.35	2.21	2.17	2.05	1.95	1.85	1.73	1.63
200	214.70	387.8	2.95	2.85	2.71	2.63	2.58	2.52	2.47	2.31	2.29	2.17	2.06	1.96	1.84	1.75

From Keenan and Keyes — Linear Interpolation. NOTE: Gauge pressure should be corrected for altitude.

CORRECTION FACTORS FOR WATER TEMPERATURES AND AIR TEMPERATURES OTHER THAN STANDARD																
AVERAGE WATER TEMP. °F	ENTERING AIR TEMPERATURE °F															
	45	55	STD 65	70	75	80	85	90	95	100	110	120	130	140	150	
90	.19	.13	.11	.06												
100	.25	.19	.15	.11	.08	.06										
110	.31	.25	.20	.16	.13	.11	.08	.06								
120	.38	.31	.26	.21	.19	.16	.13	.11	.08	.06						
130	.45	.38	.33	.28	.25	.21	.19	.16	.13	.11	.06					
140	.53	.45	.40	.34	.31	.28	.25	.21	.19	.16	.11	.06				
150	.61	.53	.45	.41	.38	.34	.31	.28	.25	.21	.16	.11	.06			
160	.69	.61	.53	.49	.45	.41	.38	.34	.31	.28	.21	.16	.11	.06		
170	.77	.69	.61	.57	.53	.49	.45	.41	.38	.34	.28	.21	.16	.11	.06	
180	.86	.77	.69	.65	.61	.57	.53	.49	.45	.41	.34	.28	.21	.16	.11	
190	.95	.86	.78	.73	.69	.65	.61	.57	.53	.49	.41	.34	.28	.21	.16	
200	1.05	.95	.86	.82	.77	.73	.69	.65	.61	.57	.49	.41	.34	.28	.21	
210	1.14	1.05	.95	.91	.86	.82	.77	.73	.69	.65	.57	.49	.41	.34	.28	
▶ 215 (STD.)	1.19	1.09	1.00	.95	.91	.86	.82	.77	.73	.69	.61	.53	.45	.38	.31	
220	1.24	1.14	1.05	1.00	.95	.91	.86	.82	.77	.73	.65	.57	.49	.41	.34	
230	1.34	1.24	1.14	1.09	1.05	1.00	.95	.91	.86	.82	.73	.65	.57	.49	.41	
240	1.44	1.34	1.25	1.19	1.14	1.09	1.05	1.00	.95	.91	.82	.73	.65	.57	.49	
250	1.55	1.44	1.34	1.29	1.24	1.19	1.14	1.09	1.05	1.00	.91	.82	.73	.65	.57	
260	1.66	1.55	1.44	1.39	1.34	1.29	1.24	1.19	1.14	1.09	1.00	.91	.82	.73	.65	
270	1.76	1.66	1.55	1.50	1.44	1.39	1.34	1.29	1.24	1.19	1.09	1.00	.91	.82	.73	
280	1.87	1.76	1.66	1.60	1.55	1.50	1.44	1.39	1.34	1.29	1.19	1.09	1.00	.91	.82	
290	1.99	1.87	1.76	1.71	1.66	1.60	1.55	1.50	1.44	1.39	1.29	1.19	1.09	1.00	.91	
300	2.10	1.99	1.87	1.82	1.76	1.71	1.66	1.60	1.55	1.50	1.39	1.29	1.19	1.09	1.00	

## DYNAMIC FORMULAS

$$BTU = GPM \times 500 \times TD$$

$$GPM = \left( \frac{BTU}{500} \right) \div TD$$

$$TD = \left( \frac{BTU}{500} \right) \div GPM$$



# SUGGESTED GENERAL SPECIFICATIONS

Furnish and install Dura-Vane II finned tube heating elements and enclosures as indicated on plans, together with required mounting components and accessories, all as manufactured by Sterling.

## HEATING ELEMENTS

All copper/aluminum heating elements shall be manufactured with seamless copper tubing mechanically expanded into the diameter of the equally spaced aluminum fins. The ends of the copper tube shall be furnished O.D. (male) and furnished I.D. (female, swaged) as to allow the use of standard domestic copper fittings.

All steel heating elements shall be manufactured with steel pressure tubing mechanically expanded into the diameter of the equally spaced steel (.024, .032) fins. The ends of the steel tube shall be threaded to accept all domestic NPT threaded fittings or cut square and chamfered for welding in field. All steel fins shall be pre-painted black with an enamel based black paint.

## BACKPLATE

All full backplates will be one piece construction, 20 gauge galvanized steel (18 gauge optional) with a die-formed mounting channel into which the enclosure shall self-locate and secure. Self-adhesive closed cell neoprene air seal gasket to be provided when requested to prevent dirt streaking (specify factory or field installed).

All partial backplates are to be machine roll formed, pre-painted, 20 gauge steel with formed mounting channel into which the enclosure shall self-locate and secure. 18 gauge partial backplates will be provided as galvanized finish. Self-adhesive closed cell neoprene air seal gasket to be provided when requested to prevent dirt streaking (specify factory or field installed).

## BRACKET HANGERS

All brackets and hangers are to be die-formed 14 gauge galvanized steel with channel type wiped edge construction for rigidity. Nickel-chromium plated ball bearings inserted into a nylon isolator insert are to be used in conjunction with an 18 gauge galvanized die-formed element support cradle to provide friction free lateral movement during expansion and contraction. Brackets are to have pre-formed contour at the top

allowing the bracket to interlock with the backplate channel. Brackets are to be self-locating in the vertical (height) position. Hangers are to provide for vertical element adjustment when pitch is required (steam). Water jobs will not require adjustable hangers. Full engagement enclosure locks are to be supplied with each bracket. Bracket locations are recommended to be 2'6" to 4'0" on center located not more than 12" in from ends of enclosure based on individual design applications.

## ENCLOSURE AND ACCESSORIES

Dura-Vane II Finned Tube Enclosures are to be of style and size as shown on plans. Material will be 16 gauge standard, 14 gauge optional, degreased and phosphatized and sealer coated cold rolled steel with a baked powder finish. Internally welded 14 gauge gussets shall occur at regular intervals to which the "pencil proof" clear anodized extruded aluminum grille will be affixed. The extruded aluminum grille is designed to engage the backplate at installation. All enclosures will be manufactured with male and female slip joints at opposing ends, providing positive engagement and alignment of adjoining enclosures at installation. The slip joints are to be of such design and form that they will provide vertical stiffening for the front skirt.

Accessories; with the exception of valve compartments; shall overlap the enclosure and fit securely with no visible fasteners. Wall sleeves shall be provided where enclosures extend to the wall. Ends shall be provided where the enclosure does not terminate at a wall. Inside and outside corners shall be furnished with no outlet grille.

## ACCESS DOORS

When indicated, access doors will be provided at mixer, shut-off or flow control valves. Doors will be 6" x 9" (or 5" x 6") and hinged at top. Access doors will be located in accessories or enclosure as noted on plans. Door latch head shall be of tamper resistant type.

## ENCLOSURES

Column enclosure kits shall be provided when piping is installed around columns. Vertical and horizontal pipe enclosures shall be provided to conceal risers and other connecting piping.





VERB C  
-venir  
yo - vengo  
tú - vienes  
usted - viene  
él/ella





**Versaline**

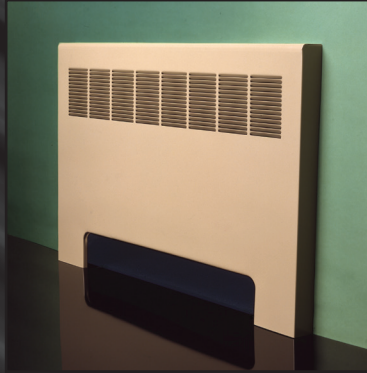

**Convactor**



**Radiant Ceiling**



**Cabinet Unit Heaters**



**Panel Radiator**



**Horizontal & Vertical Unit Heaters**



260 North Elm Street, Westfield MA 01085  
Tel: (413) 564-5535 FAX: (413) 562-8437  
[www.sterlingheat.com](http://www.sterlingheat.com)

 A MESTEK COMPANY